



Thermatel[®] Model TA2 Mass Flow Transmitter

DESCRIPTION

Thermatel Model TA2 Thermal Mass Flow Transmitter provides reliable mass measurement for air and gas flow applications. The powerful, yet easy to use, electronics are contained in a compact explosion proof enclosure. The TA2 is available with both insertion probes as well as flow body design for smaller pipe sizes. The TA2 offers excellent performance at an exceptional value.

TECHNOLOGY FEATURES

- Direct mass flow measurement of air and gases
- High turndown ratios
- Excellent low flow sensitivity
- Low pressure drop

ELECTRONICS FEATURES

- Compact explosion proof/NEMA 4X enclosure mounted either integrally on the probe or at a remote location
- 4–20 mA output can be set for either active or passive operation
- 24 VDC, 120 VAC, or 240 VAC input
- Advanced diagnostics check condition of sensor, electronics, and wiring
- Optional two-line, 16 digits per line alphanumeric display module with four push button keypad for ease of configuration
- Rotatable display module provides display of flow rate, temperature, totalized flow, plus diagnostic messages
- Electronics can be remote mounted for viewing the display
- Optional HART[®]/AMS communications



PROBE FEATURES

- All 316 welded stainless steel construction
- Hastelloy[®] C-276 construction optional
- Selection of process connections, including threads, welded flange construction, and use with compression fitting
- Process temperatures up to +400° F (+200° C)
- Pressure rating to 1500 psig (103 bar) dependent upon process connections
- Probe can be field replaced
- Sensor is protected in a window to prevent damage if inserted too far into pipe
- Optional hot tap retractable probe assembly

APPLICATIONS

- Combustion air
- Compressed air
- Natural gas
- Aeration air
- Digester/Bio-gas
- Vent lines/Flare headers
- Hydrogen lines

FLOW BODY FEATURES

- ½" to 4" pipe sizes
- NPT threads available up to 2" in size
- Stainless steel and carbon steel (with stainless steel sensor) construction
- Flange connections for all sizes
- Optional stainless steel flow conditioning plate for 1.5" and higher
- Flow conditioning for ½" to 1" based on upstream length and sensor design



ADDITIONAL FEATURES

TOTALIZER

The software totalizer provides a nine-digit display in the user's choice of engineering units. Totalized data is electronically stored eliminating the need for backup batteries, and provides maximum safeguard of data in the event of a power interruption. The totalizer can be reset using the display module or HART.

TEMPERATURE COMPENSATION

Thermal flow technology measures the mass flow rate without the need for pressure and temperature correction as required with most gas flow instruments that measure the flow rate at actual conditions. However, changing temperature will change the properties of the gas which effect convective heat transfer. The Model TA2 measures the gas temperature and automatically corrects the mass flow measurement for changes in gas properties over the entire temperature range of the instrument.

DIAGNOSTICS

Diagnostics is an important aspect of the TA2. The unit has the ability to check the probe status and indicate either normal operation, short or open circuit in the RTDs, or heater circuit.

In order to verify that the calibration and configuration match the original calibration conditions, the user can select a specific signal and compare the TA2 display value against the original calibration certificate.

SELECTABLE STP CONDITIONS

The TA2 directly measures mass flow of the gas referenced to Standard Temperature and Pressure (STP) conditions. Software permits the user to change STP conditions for their own requirements.

AREA COMPENSATION FOR PIPE SIZE

Insertion of the sensor into a pipe reduces the flow area, thus increasing the velocity for a given flow rate. The TA2 automatically compensates the flow measurement based on actual area of the pipe. The user simply enters the size or the area of the pipe, and the instrument automatically compensates the flow measurement for the probe blockage.

HART COMMUNICATION

Using the optional HART/AMS communication, the user can configure the instrument from a remote location. HART provides the same functionality as the display module interface including all configuration and diagnostic information.

AIR EQUIVALENCY

Using historic air-gas calibration data, an air equivalency calibration can be performed on select gases. Consult Magnetrol for details and flow ranges.

PROBE INSTALLATION

Probes can be provided with a variety of process connections, including threads, flanges, or installation through a compression fitting. The sensor will fit pipe sizes of 1½" diameter or larger (2" minimum size with thread connection).

The sensor is protected to prevent damage due to "bottoming-out" if inserted too far into a pipe. When using an insertion probe with compression fitting, the user can adjust the position of the sensor in the pipe to obtain the optimum location. Typically, this will be with the bottom of the probe 1 inch (25 mm) lower than the center line of the pipe.

NAMUR COMPLIANCE

Model TA2 output signal meets NAMUR NE43 recommendations for the 4–20 mA signal levels.

PORTABLE DISPLAY MODULE

A portable display module for configuration and diagnosis of multiple units is available (part number 089-5219-001). This portable module plugs into the electronics in the same manner as the normal display and uses the same software menu. This module permits the user to reduce installation cost by having one display module with keypad for multiple TA2 units.

Usage of the display module requires that the housing cover be removed during use and thus may not be useable in hazardous areas. In these cases, the HART option should be utilized.

PROBE SIMULATION MODULE

The Model TA2 has an optional probe simulation module (part number 089-5220-001). Using this module, the user can disconnect the probe from the electronics and verify the operation of the transmitter against a known standard.

FACTORY CALIBRATION AND CONFIGURATION

Each TA2 is calibrated at the factory for the type of gas and the specified flow rate. The instrument is configured for the specific application information. The result is an instrument which can be installed and immediately be placed into operation without field setup.



Portable Display Module

APPLICATIONS

COMPRESSED AIR/GASES

Measurement of mass flow in different gas lines to determine compressor efficiency or in plant usage for internal allocation.

Advantages:

- direct mass flow
- high turndown rates
- flow totalization
- easy installation

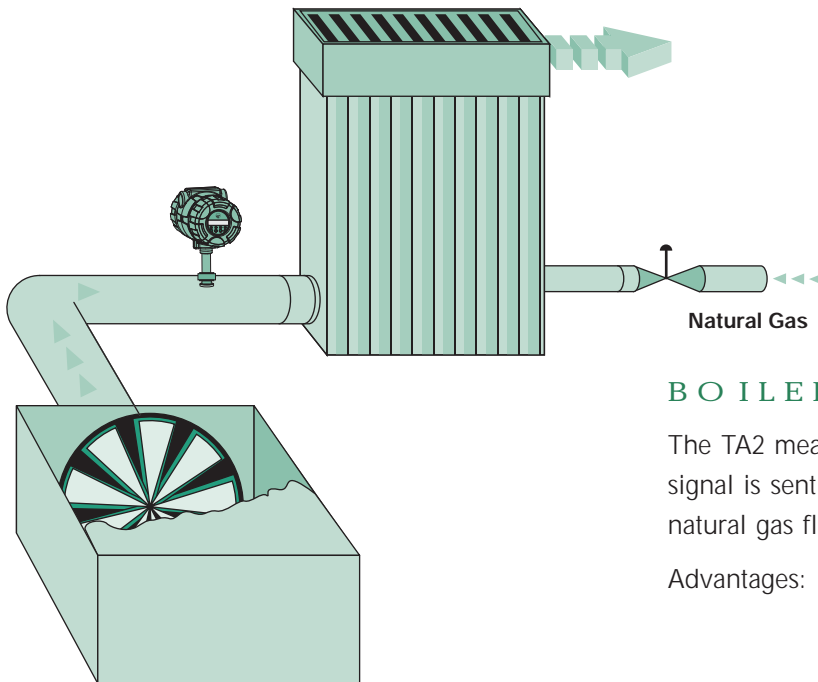
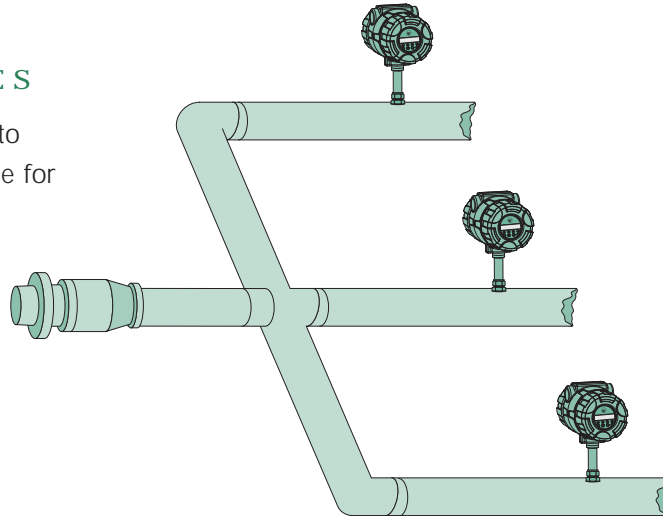

BOILER COMBUSTION

The TA2 measures the inlet air flow to the boiler. This signal is sent to the DCS where it is used to trim the natural gas flow.

Advantages:

- mass flow measurement
- repeatable flow signal
- high rangeability

NATURAL GAS FLOW

The Model TA2 efficiently measures the flow and totalized flow of fuel to furnaces, heaters, or boilers. This data may be used for internal allocation or to report emission rates.

Advantages:

- direct mass flow in SCFM
- built in totalizer
- ease in setup and operation

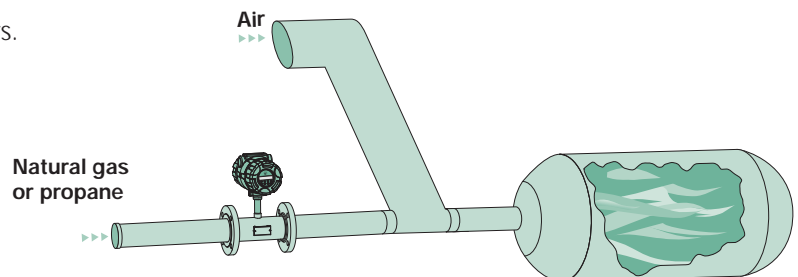

APPLICATIONS

FLARE LINES

Measurement of flow in different sections of flare line.

Advantages:

- good low flow sensitivity
- high turndown
- easy removal if cleaning is required

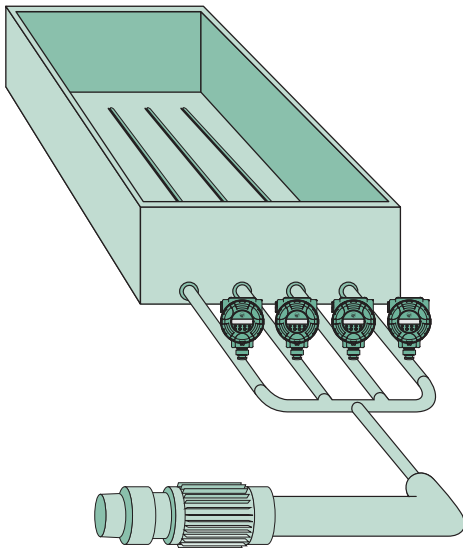
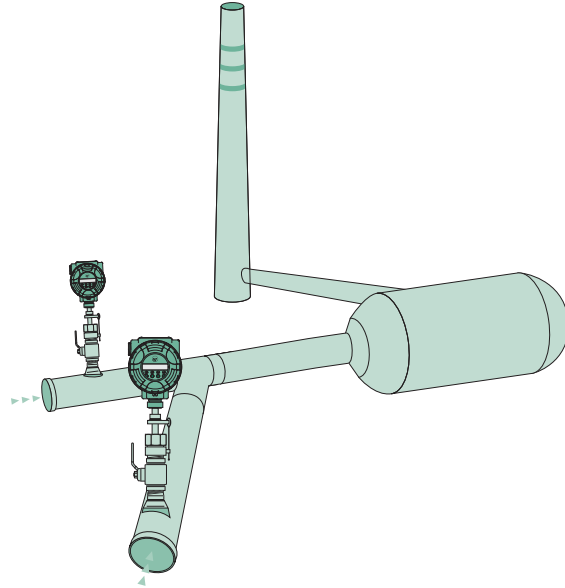

AERATION AIR FLOW

Measurement and balance of the flow to each section of the aeration basin in waste water treatment plants.

Advantages:

- low installation cost
- direct mass flow
- high reliability

DIGESTER GAS/BIO-GAS

The off gas from a digester contains a mixture of methane and carbon dioxide saturated with moisture. This is a difficult flow measurement due to low flow rate and low pressures.

Advantages:

- excellent low flow sensitivity
- high turndown rates
- provides measurement of flow and totalized flow

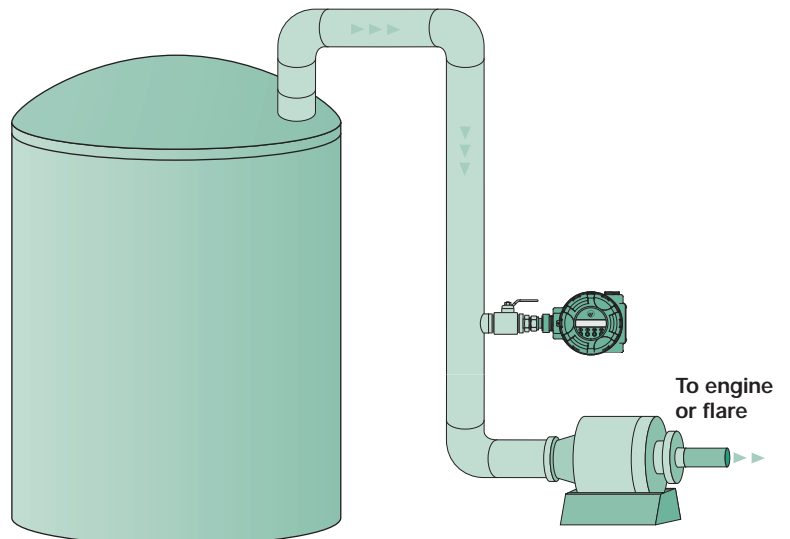

TECHNOLOGY





Thermatel Model TA2 flow transmitter measures mass flow by detecting heat dissipation from a heated surface. The sensor contains two mass balanced elements with precision matched RTDs. The reference sensor measures the process temperature (up to +400° F [+200° C]); the second RTD measures the temperature of the heated sensor. The power to the heater is varied to maintain a constant temperature difference above the reference temperature.

There is an inherent non-linear relationship between power and mass flow. The microprocessor in the TA2

compares the power against the calibration curve and converts the power requirements to the mass flow rate. Temperature is also measured to provide temperature compensation of the mass flow over the operating range of the instrument.

For further information on thermal mass flow measurement, request a copy of Magnetrol's "Thermal Dispersion Mass Flow Measurement Handbook", Bulletin 54-621.

AGENCY APPROVALS

AGENCY	APPROVED MODEL	PROTECTION METHOD	AREA CLASSIFICATION
FM  APPROVED	TA2-XXXX-X3X TA2-XXXX-X4X with TXR-XXX0-XXX (probe) TFT-XXXX-000 (flow body)	Explosion proof	Class I, Div 1, Groups B, C, & D Class II, Div 1, Groups E, F, & G Class III, T6 Ta = 160° F NEMA 4X, IP 66
		Non-Incendive	Class I, Div 2, Groups A, B, C, & D Class II, Div 2, Groups F & G Class III, T4 Ta = 160° F NEMA 4X, IP 66
CSA 	TA2-XXXX-X3X TA2-XXXX-X4X with TXR-XXX0-XXX (probe) TFT-XXXX-000 (flow body)	Explosion proof	Class I, Div 1, Groups B, C, & D Class II, Div 1, Groups E, F, & G Class III, T6 Ta = 160° F Type 4X
		Suitable for:	Class I, Div 2, Groups A, B, C, & D Class II, Div 2, Groups E, F, & G Class III, T4 Ta = 160° F Type 4X
ATEX 	TA2-XXXX-XCX TA2-XXXX-XDX with TXR-XXX0-XXX (probe) TFT-XXXX-000 (flow body)	Explosion proof	 II 2 G EEx d IIC T6

 These units have been tested to EN 61326 and are in compliance with the EMC Directive 89/336/EEC.

SPECIFICATIONS

PERFORMANCE / PHYSICAL

Flow range maximum	10–40,000 SFPM (0.13–200 Nm/s) air reference to standard conditions Higher ranges and other gases available; contact factory
Flow range minimum	10–500 SFPM (0.13–2.5 Nm/s) air reference to standard conditions
Accuracy flow	±1% of reading +0.5% of calibrated full scale
Accuracy temperature	±2° F (1° C)
Repeatability	±0.5% of reading
Linearity	Included in flow accuracy
Temperature effect	±0.04% per ° C
Turn down	100:1 typical (depending on calibrated flow range)
Calibration	NIST traceable
Ambient temperature	-40° F to +160° F (-40° C to +70° C); display not readable below -4° F (-20° C)
Storage temperature	-60° F to +160° F (-50° C to +70° C) blind units only
Display	Two-line alphanumeric LCD, 16-characters per line
Keypad	Four pushbutton
Menu language	English, French, German
Humidity	99% Non-condensing
Supply voltage	120 VAC, 50–60 Hz, +10%/–15% VAC ~ 240 VAC, 50–60 Hz, +10%/–15% VAC ~ 24 VDC ±20% VDC ===
Power consumption	6 watts, 9 VA
Analog output signal	
Active	4–20 mA (isolated) maximum 1000 Ω loop resistance
Passive	4–20 mA (isolated) loop resistance dependent on power supply
Diagnostic alarm	3.6 mA, 22 mA, HOLD
HART	Optional
Response time	1 to 2 second time constant typical
Cable length	50 feet; 150 feet if cable supplied by Magnetrol. Longer lengths possible.
Housing material	Aluminum A356 (<0.2% copper)
SIL	Safe Failure Fraction (SFF) 69%

PROBE

Materials	316/316L stainless steel all welded Hastelloy C-276 optional
Process connections	Refer to model number, hot tap optional
Process pressure	1500 psig @ +70° F (103 bar @ +20° C), 1375 psig @ +400° F (95 bar @ +200° C)
Temperature rating	-50° to +400° F (-45° to +200° C)①

FLOW BODY

Materials	316/316L stainless steel all welded Carbon steel with stainless steel sensor
Process connections	NPT or 150 lb. flange – Refer to Model Number
Pressure rating	1500 psig @ +70° F (103 bar @ +20° C), 1100 psig @ +400° F (79 bar @ +200° C) dependent upon process connections
Temperature rating	-50° to +400° F (-45° to +200° C)①

① For operating temperatures between +250° F and +400° F (+120° C and +200° C), either use remote electronics or a longer length insertion probe to provide an additional four inches (100 mm) between the electronics and the compression fitting.

RETRACTABLE PROBE ASSEMBLY

HOT TAP

Two methods are offered of removing the probe from the pipe without having to shut down the process. The Hot Tap Retractable Probe Assembly (RPA) is designed to meet API (American Petroleum Institute) standards. The less demanding valve and compression fitting (part number 089-5218-001) will have some minor leakage when the probe is removed or re-inserted and does not have the safety cable to prevent "blow out" of the probe when removed under pressure.

RPA requires a probe with 3/4" NPT process connection (code 11).

The valve with compression fitting uses a 1" NPT connection while the RPA uses a 1/2" NPT connection.

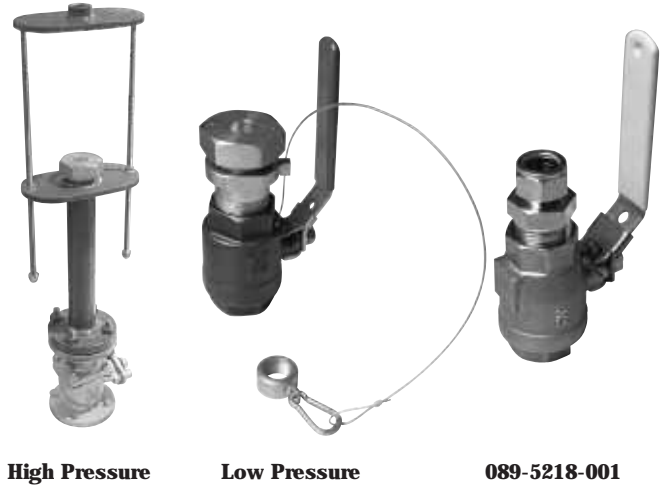

BASIC MODEL NUMBER

RPA	Retractable probe assembly
-----	----------------------------

DESIGN TYPE

5	Low pressure (up to 80 psi, 5.5 bar), length in tenth of an inch
6	High pressure (up to 300# class service), length in tenth of an inch
E	Low pressure (up to 80 psi, 5.5 bar), length in centimeters
F	High pressure (up to 300# class service), length in centimeters

MATERIALS OF CONSTRUCTION

1	Carbon steel (available on flange and high pressure units). Seal gland is 316 stainless steel.
4	316 stainless steel

PROCESS CONNECTION

0	1/2" NPT
1	1/2" 150# flange
2	1/2" 300# flange

BALL VALVE

0	No ball valve supplied
1	Carbon steel
2	Stainless steel

PROBE LENGTH

10 to 99.9 inches (example: 12" = 120)
25 to 253 centimeters (example: 30 cm = 030)

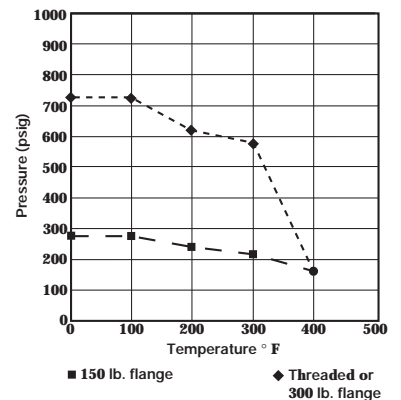

DIMENSIONAL SPECIFICATIONS

HOT TAP – inches (mm)

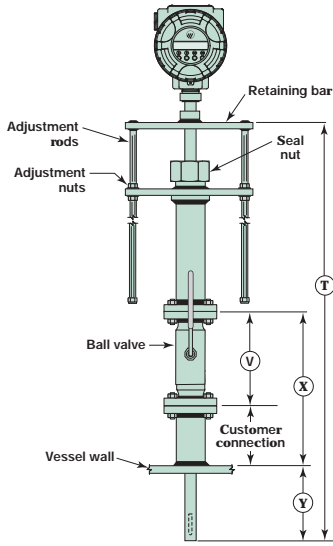

**Hot Tap
Model RPA-6X12-XXX**
Minimum Probe Length:
 $T = 2(X+Y)$

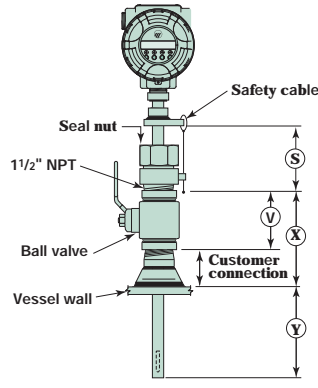

**Hot Tap
Model RPA-5402-XXX**
Minimum Probe Length
 $= S+X+Y$

S Dimension	
Threaded conn.	4.0 (102)
Flanged conn.	5.0 (127)

Ball Valve Dimensions*	
Size	V
1 1/2" NPT	4.4 (112)
1 1/2" 150# flange	6.5 (165)
1 1/2" 300# flange	7.5 (191)

*Dimension of ball valve if supplied by Magnetrol.

Dimension V:
Ball valve dimension (see chart)

Dimension X:
Length from wall to top of ball valve

Dimension Y:
Insertion length into pipe

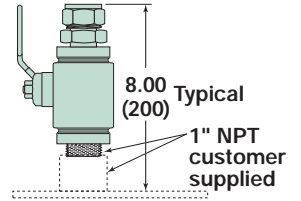

**Valve with
Compression Fitting
(089-5218-001)**

INTEGRAL MOUNT – inches (mm)

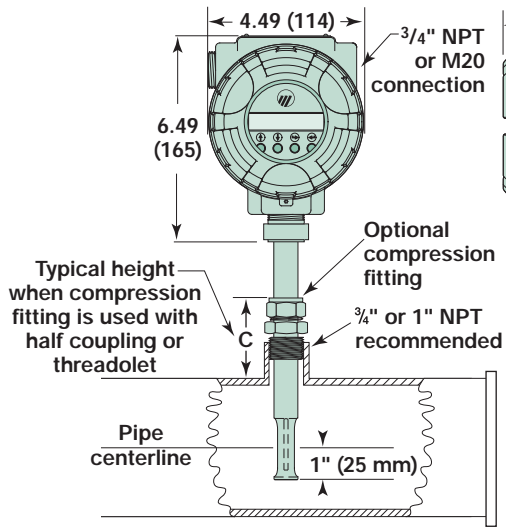

**Integral Mount Model TA2
Front and Side Views**

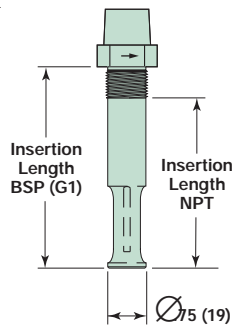
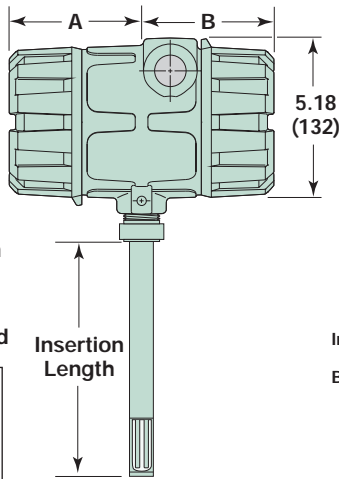

**TXR with
Threaded Connection**

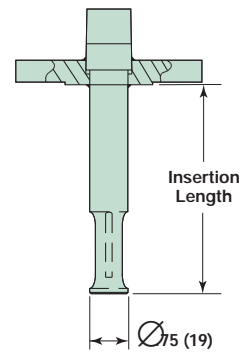

**TXR with
Flanged Connection**

Process Conn. Size	Height C	Compression fitting	
		Teflon ferrules	Stainless steel ferrules
1" NPT	3.1 (79)	011-4719-009 (100 psi maximum)	011-4719-007 (1500 psi maximum)
3/4" NPT	2.6 (66)	011-4719-008 (100 psi maximum)	011-4719-006 (1500 psi maximum)

Dimension A:
3.33 (85) without display
3.88 (89) with display

Dimension B:
3.88 (89)

DIMENSIONAL SPECIFICATIONS

REMOTE MOUNT – inches (mm)

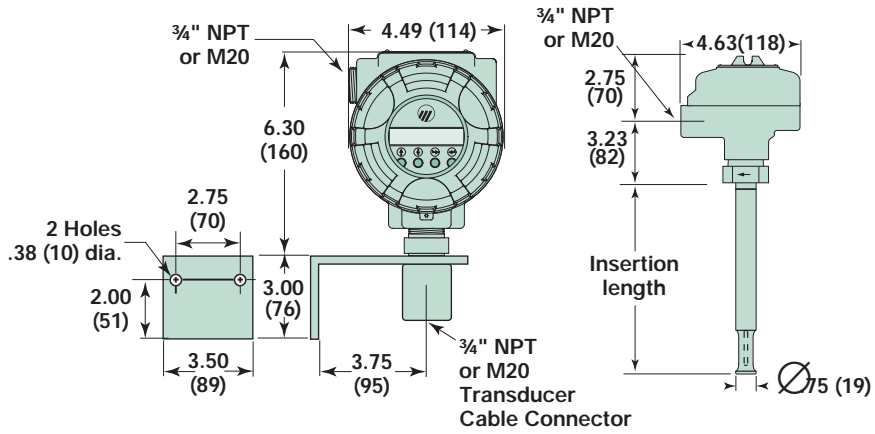

Remote Mount Model TA2

FLOW BODY – see chart at right

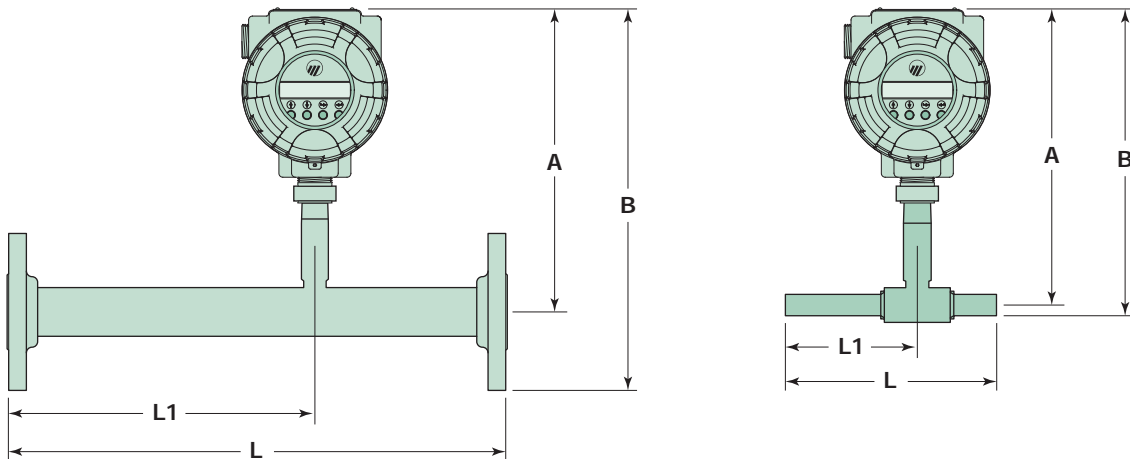

FLOW BODY SIZING

The following table is a general guide on flow sizing. Contact Magnetrol or your local representative for specific application information.

Code	Size	Air, N ₂ , O ₂	Natural Gas, Methane	Digester Gas	Propane	Hydrogen	CO ₂ , Argon
0	½"	65 SCFM 110 NM ³ /h	45 SCFM 76 NM ³ /h	25 SCFM 42 NM ³ /h	30 SCFM 51 NM ³ /h	15 SCFM 27 NM ³ /h	60 SCFM 105 NM ³ /h
1	¾"	120 SCFM 204 NM ³ /h	85 SCFM 140 NM ³ /h	45 SCFM 76 NM ³ /h	55 SCFM 93 NM ³ /h	30 SCFM 52 NM ³ /h	110 SCFM 190 NM ³ /h
2	1"	200 SCFM 340 NM ³ /h	140 SCFM 238 NM ³ /h	75 SCFM 127 NM ³ /h	95 SCFM 161 NM ³ /h	50 SCFM 85 NM ³ /h	190 SCFM 320 NM ³ /h
3	1½"	490 SCFM 833 NM ³ /h	340 SCFM 580 NM ³ /h	180 SCFM 310 NM ³ /h	230 SCFM 395 NM ³ /h	120 SCFM 208 NM ³ /h	465 SCFM 790 NM ³ /h
4	2"	715 SCFM 1220 NM ³ /h	505 SCFM 855 NM ³ /h	280 SCFM 480 NM ³ /h	350 SCFM 600 NM ³ /h	195 SCFM 332 NM ³ /h	680 SCFM 1155 NM ³ /h
5	3"	1765 SCFM 3000 NM ³ /h	1240 SCFM 2110 NM ³ /h	695 SCFM 1180 NM ³ /h	860 SCFM 1470 NM ³ /h	475 SCFM 812 NM ³ /h	1680 SCFM 2855 NM ³ /h
6	4"	3230 SCFM 5490 NM ³ /h	2260 SCFM 3845 NM ³ /h	1265 SCFM 2145 NM ³ /h	1575 SCFM 2675 NM ³ /h	865 SCFM 1478 NM ³ /h	3060 SCFM 5210 NM ³ /h

FLOW BODY DIMENSIONS CHART

inches (mm)

Code	Size	Length (L)		L1		Height to Centerline (A)	Overall Height (B)	
		With Flow Conditioning	Without Flow Conditioning	With Flow Conditioning	Without Flow Conditioning		NPT	Flange
0	½"	8 (203)	—	5 (127)	—	8.0 (203)	8.7 (221)	9.75 (248)
1	¾"	11.25 (285)	—	7.5 (190)	—	8.0 (203)	8.7 (221)	9.9 (251)
2	1"	15 (381)	—	10 (254)	—	8.0 (203)	8.7 (221)	10.1 (257)
3	1½"	19.5 (495)	7.5 (191)	12 (305)	3.75 (95)	8.35 (212)	9.3 (236)	10.85 (276)
4	2"	26 (660)	7.5 (191)	16 (406)	3.75 (95)	9.25 (235)	10.4 (264)	12.25 (311)
5	3"	39 (991)	10 (254)	24 (610)	5 (127)	9.25 (235)	N/A	13.0 (330)
6	4"	52 (1321)	12 (305)	36 (914)	6 (152)	9.25 (235)	N/A	13.75 (349)

Flow conditioning on ½" to 1" is provided due to length of flow body and sensor design.

Optional flow conditioning plate is available on flow bodies 1½" and larger.

MODEL NUMBER

TRANSMITTER WITH INSERTION PROBE

Models available for quick shipment, usually within one week after factory receipt of a purchase order, through the Expedite Ship Plan (ESP)

INPUT VOLTAGE

0	120 VAC
1	240 VAC
2	24 VDC

SIGNAL OUTPUT

0	4-20 mA
1	4-20 mA with HART

DISPLAY

0	None
B	Plug in display with keypad (with window)

LANGUAGE

1	English
3	French
4	German

CALIBRATION

Actual Gas Calibration	
0	Special
1	Air
2	Nitrogen or Oxygen
3	Hydrogen
4	Natural Gas
5	Methane
6	Digester Gas
7	Propane
Air Equivalency Calibration	
9	Air Equivalency

HOUSING LOCATION / AGENCY APPROVAL

3	Integral, general purpose, non-incendive, & explosion proof FM/CSA (Groups B, C, & D)
4	Remote, general purpose, non-incendive, & explosion proof FM/CSA (Groups B, C, & D)
C	Integral, general purpose, Ex d ATEX
D	Remote, general purpose, Ex d ATEX

ENCLOSURE TYPE

0	Aluminum, 3/4" NPT
1	Aluminum, M20

T	A	2	—					—			
----------	----------	----------	---	--	--	--	--	---	--	--	--

MODEL NUMBER

INSERTION PROBE

UNIT OF MEASUREMENT

TER	Probe length in tenths of inches
TMR	Probe length in centimeters

MATERIALS OF CONSTRUCTION

A	316/316L stainless steel
B	Hastelloy C

PROCESS CONNECTION

00	Compression fitting utilized ^{①②}	43	2" 150# ANSI raised face flange
11	3/4" NPT	44	2" 300# ANSI raised face flange
21	1" NPT	BA	DN25 PN 16, EN 1092-1, Type A
22	1" BSP (G1)	BB	DN25 PN 25/40, EN 1092-1, Type A
23	1" 150# ANSI raised face flange	CA	DN40 PN 16, EN 1092-1, Type A
24	1" 300# ANSI raised face flange	CB	DN40 PN 25/40, EN 1092-1, Type A
33	1 1/2" 150# ANSI raised face flange	DA	DN50 PN 16, EN 1092-1, Type A
34	1 1/2" 300# ANSI raised face flange	DB	DN50 PN 25/40, EN 1092-1, Type A

① Not available with Hastelloy C construction
 ② Customer supplied or purchased separately (see page 9 for part numbers)

PROBE LENGTH

2.6 to 99.9 inches (example: 8.5" = 085) Minimum lengths: 2.6" (026) with threaded process connection 2.8" (028) with flanged process connection 4.5" (045) with compression fitting process connection
7 to 253 centimeters (example: 18 cm = 018) Minimum lengths: 7 cm (007) with NPT or flanged process connection 9 cm (009) with BSP threads 11 cm (011) with compression fitting process connection
Model TER-A000-080 is available through the Expedite Ship Plan

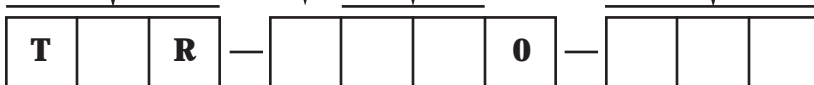

MODEL NUMBER

CONNECTING CABLE

CABLE LENGTH IN FEET

10 feet minimum, 150 feet maximum length Example: 50 feet = 050
--

Longer cable lengths possible. Consult factory with application details.

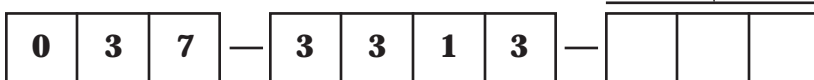

CABLE LENGTH IN METERS

3 meters minimum, 45 meters maximum length Example: 8 meters = 008

Longer cable lengths possible. Consult factory with application details.

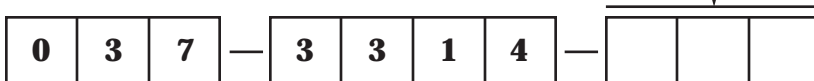

MODEL NUMBER

TRANSMITTER WITH FLOW BODY

INPUT VOLTAGE

0	120 VAC
1	240 VAC
2	24 VDC

SIGNAL OUTPUT

0	4–20 mA
1	4–20 mA with HART

DISPLAY

0	None
B	Plug in display with keypad (with window)

LANGUAGE

1	English
3	French
4	German

CALIBRATION

Actual Gas Calibration	
A	Special
B	Air
C	Nitrogen or Oxygen
D	Hydrogen
E	Natural Gas
F	Methane
G	Digester Gas
H	Propane
Air Equivalency Calibration	
K	Air Equivalency

HOUSING LOCATION / AGENCY APPROVAL

3	Integral, general purpose, non-incendive, & explosion proof FM/CSA (Groups B, C, & D)
4	Remote, general purpose, non-incendive, & explosion proof FM/CSA (Groups B, C, & D)
C	Integral, general purpose, Ex d ATEX
D	Remote, general purpose, Ex d ATEX

ENCLOSURE TYPE

0	Aluminum, 3/4" NPT
1	Aluminum, M20



MODEL NUMBER

FLOW BODY

MATERIALS OF CONSTRUCTION

A	All stainless steel
1	Carbon steel body with stainless steel sensor

SIZE

0	½ inch
1	¾ inch
2	1 inch
3	1½ inch
4	2 inch
5	3 inch
6	4 inch

PROCESS CONNECTION TYPE

1	NPT Threads (only when Digit 5 = 0, 1, 2, 3, or 4)
3	150# Flange

FLOW CONDITIONING PLATE (stainless steel)

0	Not provided
1	Provided (only when Digit 5 = 3, 4, 5, or 6)

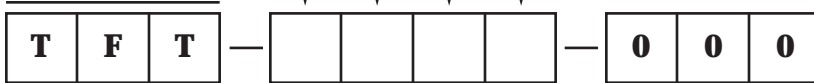

MODEL NUMBER

CONNECTING CABLE

CABLE LENGTH IN FEET

10 feet minimum, 150 feet maximum length
Example: 50 feet = 050

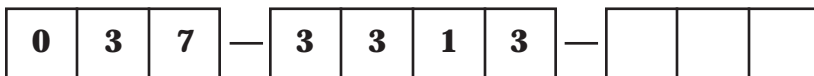

Longer cable lengths possible.
Consult factory with application details.

CABLE LENGTH IN METERS

3 meters minimum, 45 meters maximum length
Example: 8 meters = 008

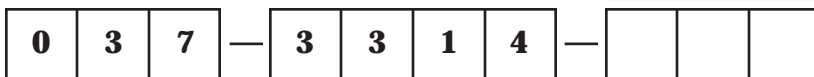

Longer cable lengths possible.
Consult factory with application details.

Q U A L I T Y



The quality assurance system in place at Magnetrol guarantees the highest level of quality throughout the company. Magnetrol is committed to providing full customer satisfaction both in quality products and quality service.

Magnetrol's quality assurance system is registered to ISO 9001 affirming its commitment to known international quality standards providing the strongest assurance of product/service quality available.

E S P

E xpedite S hip P lan

Model TA2-01B1-130 with 8" probe Model TER-A000-080 is available for quick shipment, usually within one week after factory receipt of a purchase order, through the Expedite Ship Plan (ESP).

ESP service may not apply to orders of ten units or more. Contact your local representative for lead times on larger volume orders, as well as other products and options.

W A R R A N T Y



All Magnetrol electronic level and flow controls are warranted free of defects in materials or workmanship for one full year from the date of original factory shipment.

If returned within the warranty period; and, upon factory inspection of the control, the cause of the claim is determined to be covered under the warranty; then, Magnetrol will repair or replace the control at no cost

to the purchaser (or owner) other than transportation.

Magnetrol shall not be liable for misapplication, labor claims, direct or consequential damage or expense arising from the installation or use of equipment. There are no other warranties expressed or implied, except special written warranties covering some Magnetrol products.

Additional information

The following additional Thermatel literature is available from your local representative:

- 54-630 Thermatel Model TA2 Mass Flow Transmitter Instruction Manual and Parts List
- 54-100 Thermatel Technology brochure
- 54-105 Thermatel TG1 Flow and Level Switch sales literature
- 54-110 Thermatel Model TD1/TD2 Thermal Dispersion Flow and Level Switch sales literature
- 54-120 Thermatel Model TA1 Mass Flow Transmitter sales literature
- 54-131 Thermatel Model TA1/TA2 Probe location literature
- 54-210 Thermal Dispersion Mass Flow Meter Applications
- 54-621 Thermal Dispersion Mass Flow Measurement Handbook



5300 Belmont Road • Downers Grove, Illinois 60515-4499 • 630-969-4000 • Fax 630-969-9489 • www.magnetrol.com
145 Jardin Drive, Units 1 & 2 • Concord, Ontario Canada L4K 1X7 • 905-738-9600 • Fax 905-738-1306
Heikensstraat 6 • B 9240 Zele, Belgium • 052 45.11.11 • Fax 052 45.09.93
Regent Business Ctr., Jubilee Rd. • Burgess Hill, Sussex RH15 9TL U.K. • 01444-871313 • Fax 01444-871317

Copyright © 2007 Magnetrol International, Incorporated. All rights reserved. Printed in the USA.
Performance specifications are effective with date of issue and are subject to change without notice.

Magnetrol & Magnetrol logotype and Thermatel are registered trademarks of Magnetrol International
CSA logotype is a registered trademark of Canadian Standards Association
HART is a registered trademark of the HART Communication Foundation
Hastelloy is a registered trademark of Haynes International, Inc.

BULLETIN: 54-130.5
EFFECTIVE: August 2007
SUPERSEDES: March 2006