

# TORBAR<sup>®</sup>

INCORPORATING

**TRIBAR & MASS TRIBAR**

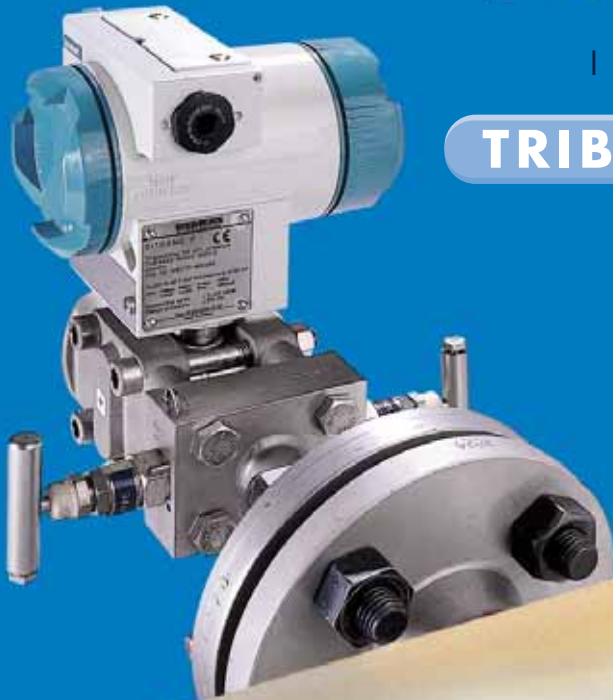

FOR DEPENDABLE FLOW MEASUREMENT

## WHAT IS A TORBAR?

The **TORBAR** is a multiport self-averaging flow meter with a design based on the classical pitot tube concept of fluid flow measurement.

Since the introduction of the **TORBAR** in 1985, thousands have been installed into a wide variety of industries world wide. Refer to page 14 for details of typical applications where Torbars have been successfully used.

A comprehensive list of major projects and letters of reference from international companies are available on request.

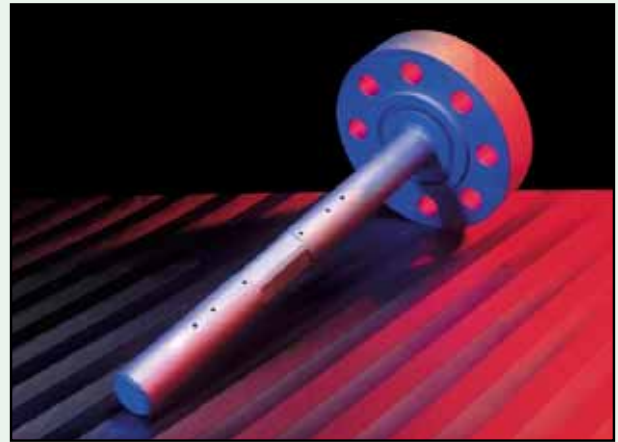

## HOW TORBAR WORKS

**TORBAR** produces an averaged differential pressure (DP) signal proportional to the square of the flow rate, (see Differential Pressure Calculations on page 11).

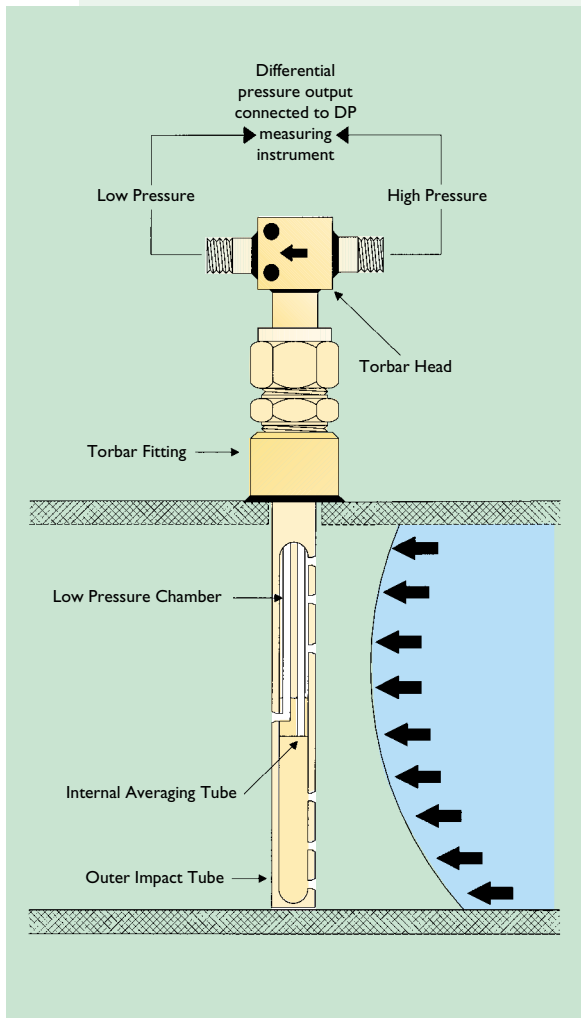

The DP output is normally piped to a Differential Pressure Transmitter in order to generate an electrical signal proportional to the flow rate. A D.P. gauge or switch can be used to provide local mechanical indication or flow rate switching. For certain applications, the DP Transmitter can be directly mounted on to the **TORBAR** via an integral 3 valve manifold. The total flowmeter package is called a **TRIBAR**. Full details are given on pages 16 & 17.

Each **TORBAR** is designed to span the process pipe diameter and comprises four basic components:

- **Outer impact tube - ONE PIECE CONSTRUCTION**
- **Internal averaging tube**
- **Low pressure chamber**
- **Head**

The outer impact tube has a number of pressure sensing holes facing upstream which are positioned at equal annular points in accordance with a log-linear distribution.

The "total pressures" developed at each upstream hole by the impact of the flowing medium are firstly averaged within the outer impact tube and then to a second order (and more accurately) averaged within the internal averaging tube. This pressure is represented at the head as the high pressure component of the DP output.

The low pressure component is generated from a single sensing hole located on the downstream side of the outer impact tube. For bi-directional flow measurement, the **TORBAR** can be supplied with the same number of downstream ports as upstream. Bi-directional sensors have an inherently lower mechanical strength than the standard **TORBAR** and the figures given for Maximum Allowable DP on page 11 should be reduced by 50%.

**PROFILE SHAPE** - The **TORBAR** is an improvement on the round sensor design due to the unique profiled flats which are positioned around the downstream hole in order to define the separation point at which the flow lines "break-off" as the fluid passes around the outer impact tube. This feature creates a stable pressure area at the downstream pressure sensing hole thereby maintaining a more constant flow co-efficient K at high velocities enabling a very wide range of flow measurement (turndown).

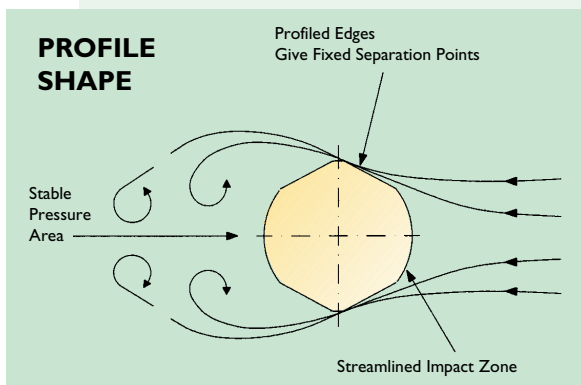

## PROBLEM FLUIDS

The **TORBAR** is NOT suitable for the measurement of 2 phase fluids or when the fluid does not completely fill the cross section of the pipe.

Satisfactory flow measurement can be achieved for certain contaminated gas flows (such as flue gas) by using an air purging system. See page 15. For water flows which may contain a small amount of air, an air-venting package is recommended.

## FEATURES

- Unique profile shape enables high flow turndown
- Dual averaging for better accuracy
- One-piece outer tube for optimum strength
- Suitable for pipe sizes from 10mm to 5000mm (and larger with a special 2 piece construction)
- Suitable for square or rectangular section ducts
- Available as hot-tap for insertion into pressurised pipes
- Optional direct mounting transmitter arrangement (see TRIBAR on pages 16 & 17)
- Zero co-efficient drift ensures long term stability
- Low permanent pressure loss means low energy consumption - and significant cost benefits



## GENERAL SPECIFICATIONS

- TORBAR is suitable for liquid, gas, and steam flow measurement
- Accuracy  $\pm 1\%$  of actual flow rate - verified by independent flow laboratories
- Repeatability of measurement  $\pm 0.1\%$
- Reynolds number. Minimum  $Re: 1.2 \times 10^4$
- Flow rate turndown typically 10:1 (100:1 of DP)
- Maximum working pressure up to 600 bar
- Maximum working temperature up to 1300 deg. C with selected materials and fittings
- Maximum viscosity 200 cp (mPas)
- Short upstream and downstream straight pipe lengths
- Long term accuracy unaffected by wear

## CONSTRUCTION

- TORBARs are engineered and manufactured to stringent routines including BS, ANSI, ASME, ISO and DIN standards
- Welding is carried out by Lloyds qualified welders to ASME IX and European standards.
- Quality control system is approved to BS EN ISO 9002-1994
- TORBARs are leak tested before dispatch.
- Hydrostatic pressure testing and NDE is available by request for all models.
- Standard material of construction is 316L stainless steel but many other materials are available on request.
- All TORBARs have full material traceability.
- Material test certificates to EN 10204 (DIN 50049) and certificates of conformity are available for each component part of every TORBAR
- Stainless steel data plate as standard.



## INDEPENDENT FLOW TESTS

The **TORBAR** accuracy and repeatability of measurement has been verified by independent testing laboratories in the United Kingdom. Refer to page 10 for more details.

# PERMANENTLY INSTALLED TYPES

## MODEL SPECIFICATION

### IN LINE FITTING

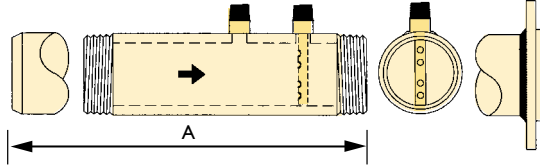

BASIC MODEL	END FITTINGS	FITS PIPE SIZES (mm)
121	Butt Weld	13 - 50
122	Threaded	
123	Flanged	

All models are supplied with a pipe section in the same material as **TORBAR** probe

PIPE SIZE (INS.SCH80)	'A' (mm)	MODEL	MAXIMUM PRESSURE/TEMPERATURE
1/2"	200	121	200BAR/450°C
1"	225	122	70BAR/200°C
1 1/2", 2"	250	123	As flange rating

### THREADED FITTING

BASIC MODEL	D (mm)	FITS PIPE SIZES (mm)
301	13	50 - 150
401†	25	100 - 1800
402*	25	100 - 5000

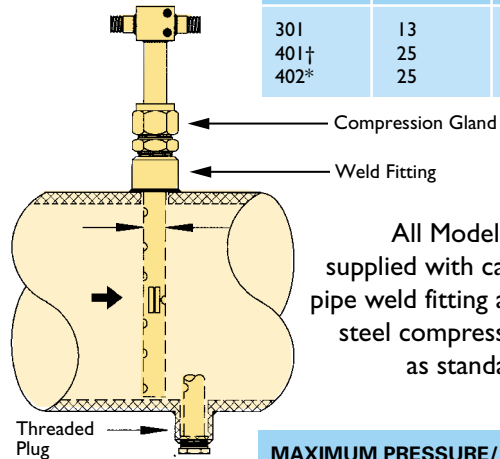

All Models are supplied with carbon steel pipe weld fitting and stainless steel compression gland as standard.

#### MAXIMUM PRESSURE/TEMPERATURE

Model 301	70 Bar @ 500°C
Model 401, 402	70 Bar @ 500°C

#### End Support Model 402

† For liquid flow applications where there is a possibility of process pulsations or intermittent excessive flow velocity, the end-support model should always be selected for pipe sizes over 250mm internal diameter.

\* With end support

### FLANGED FITTING

#### Standard

BASIC MODEL	D (mm)	FITS PIPE SIZES (mm)
311	13	50 - 150
411†	25	100 - 1800
412*	25	100 - 5000

All Models are standardly supplied without flanged pipe fitting or stud bolts and gaskets. These are available as accessories

#### STANDARD FLANGE SIZE

Model 311	1 inch (DN 25)
Model 411, 412	1 1/2 inch (DN 40)
(Other sizes available)	

#### MAXIMUM PRESSURE/TEMPERATURE

ALL MODELS AS FLANGE RATING TO 450°C FOR MATERIAL 316LSS

† For liquid flow applications where there is a possibility of process pulsations or intermittent excessive flow velocity, the end-support model should always be selected for pipe sizes over 250mm internal diameter.

\* With end support

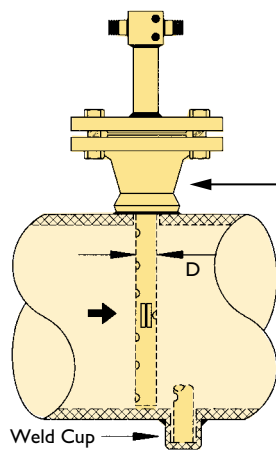

#### End Support Model 412

### FLANGED FITTING

#### Extra Strength

BASIC MODEL	D (mm)	FITS PIPE SIZES (mm)
511†	60	250 - 1800
512*	60	400 - 8000

All Models are standardly supplied without flanged pipe fitting or stud bolts and gaskets. These are available as accessories

#### STANDARD FLANGE SIZE

Model 511, 512	3 inch (DN 80)
Other sizes available	

#### MAXIMUM PRESSURE/TEMPERATURE

ALL MODELS AS FLANGE RATING TO 450°C FOR 316L SS

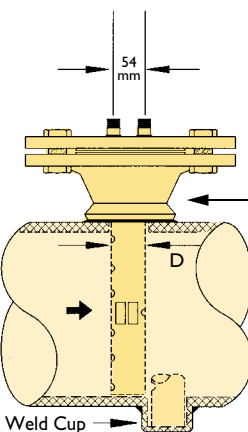

#### End Support Model 512

† For liquid flow applications where there is a possibility of process pulsations or intermittent excessive flow velocity, the end-support model should always be selected for pipe sizes over 600mm internal diameter.

\* With end support

**FOR VERTICAL PIPE INSTALLATIONS, SPECIFY OPTION 'VS' - SEE PAGE 12**

# PERMANENTLY INSTALLED TYPES

## MODEL CODING

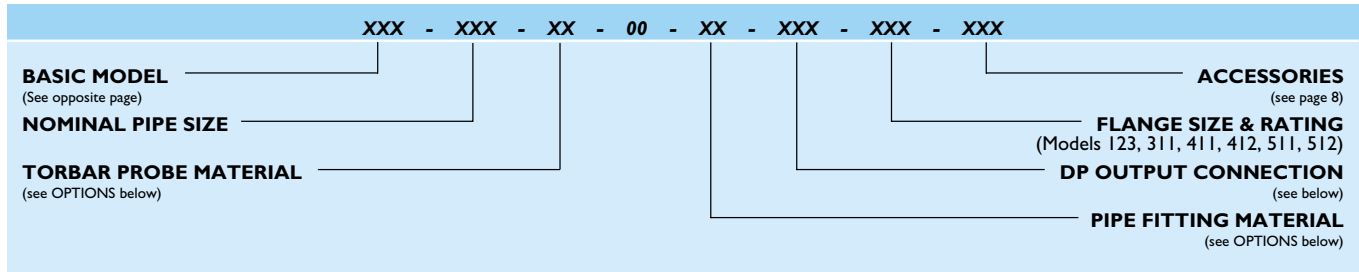

### OPTIONS

PROBE MATERIAL	CODE	PIPE FITTINGS MATERIAL	CODE
316L Stainless steel	SS	A105 Carbon steel	CS
304 Stainless steel	4S	316L Stainless steel	SS
Monel 400	ML	304L Stainless steel	4S
Hastelloy	HC	Monel 400	ML
6MO	6M	Hastelloy	HC
Duplex	DX	6MO	6M
Super Duplex	SDX	Duplex	DX
Plastic	PC	Super Duplex	SDX
Titanium GR2	TI	Other	Specify
Other	Specify	Purchaser Supply	XX

### DP OUTPUT CONNECTIONS

X X X

VALVE MATERIAL	CODE	VALVE TYPE	CODE	SIZE	CODE
No valves	O	No valves	O	DM or DM3V HEAD (See Accessories page 8)	0
DM or DM3V HEAD	O	DM or DM3V HEAD	O	1/4" NPT (M)	3
Brass	B	Ball	B	1/4" BSPT (M)	4
Carbon Steel	C	Needle	V	1/2" NPT (M)	7
316L Stainless Steel	S	Needle (High Temp)	VH	1/2" BSPT (M)	8
Monel 400 (Or Alloy 400)	ML	Gate	G	1/2" WELD (MALE)	6
UNS 31254 (6MO)	6M	Globe	L	1/2" FLANGED	9
Hastelloy (C276)	HC	Double Block/Bleed	VD	OTHER	SPECIFY
Other	SPECIFY				

**NOTE:** For a female output connection WITHOUT valves, add 'F' to size-code. eg. 1/4" NPT female connection without valves, code is 003F.

MALE WITHOUT VALVES	FEMALE WITHOUT VALVES	FLANGED WITHOUT VALVES
Code Example: 007 (1/2" NPT) 	Code Example: 006F (1/2" Weld Socket) 	Code Example: 009 (1/2") 
WITH NEEDLE VALVES	WITH BALL VALVES	WITH GATE VALVES
Code Example: SV4 (ST. ST. 1/4" BSPT) 	Code Example: BB3 (BRASS. 1/4" NPT) 	Code Example: CG8 (Carbon ST. 1/4" BSPT) 
DIRECT MOUNT HEAD	DIRECT MOUNTING WITH MANIFOLD	DIRECT MOUNT INTEGRAL MANIFOLD
Code: 000 Specify Accessory: DM 	Code: 000 Specify Accessory: 3VDM (3 Valve) 5VDM (5 Valve) 	Code: 000 Specify Accessory: DM3V 

# WITHDRAWABLE TYPES (HOT TAP)

## MODEL SELECTION

### THREADED FITTING

LOW PRESSURE

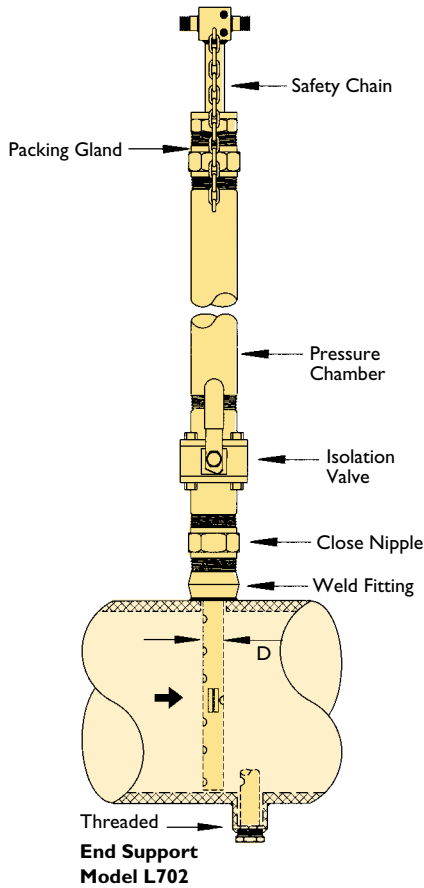

### THREADED FITTING

HIGH PRESSURE

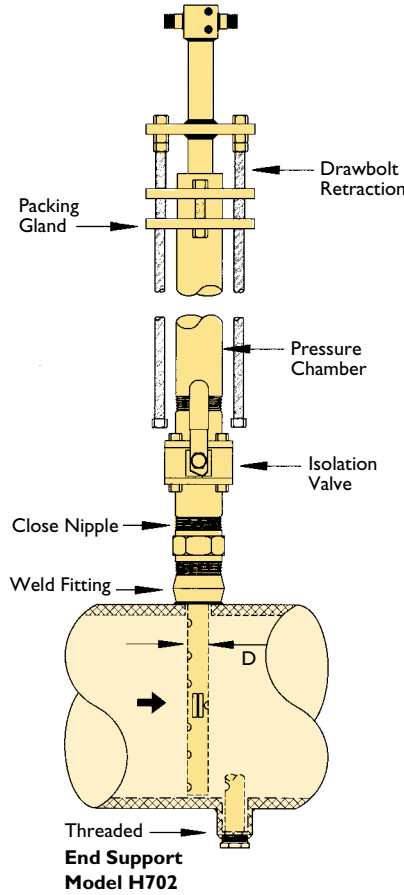

### FLANGED FITTING

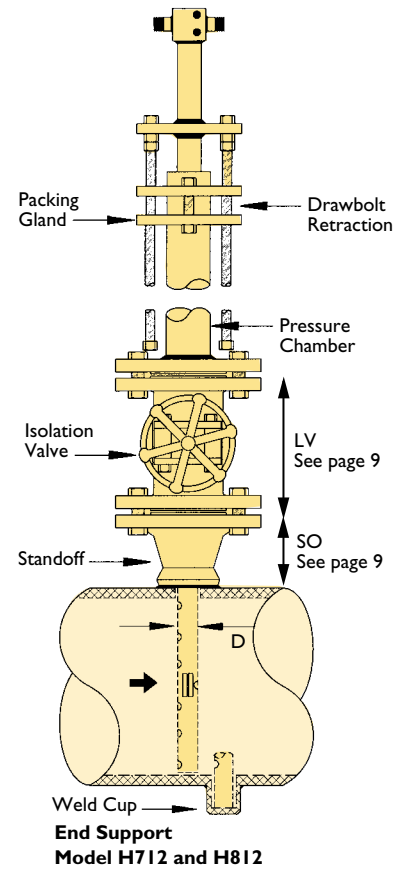

**Models L702, H702, H712 and H812 should not be installed into a pressurised pipe because of the requirement to fit an end support. Refer to detailed installation instructions.**

BASIC MODEL	D (mm)	FITS PIPE SIZES (mm)
L601	13	50 - 100
L701†	25	100 - 1800
L702*	25	300 - 3000

Supplied with weld fittings, isolation valve and pressure chamber with safety chain as standard. Gland packing material is standardly supplied as non-asbestos graphite ribbon. Teflon is available.

Please specify at time of order.

For isolation valve details - see page 7.

#### MAXIMUM PRESSURE / TEMPERATURE

With standard ball valve 10 bar and 200°C  
With standard gate valve 10 bar and 450°C  
(Temperature is at valve)

† For liquid flow applications where there is a possibility of process pulsations or intermittent excessive flow velocity, the end-support model should always be selected for pipe sizes over 250mm internal diameter.

\*with end support

BASIC MODEL	D (mm)	FITS PIPE SIZES (mm)
H601	13	050 - 100
H701†	25	100 - 1800
H702*	25	300 - 3000

Supplied with weld fittings, isolation valve, pressure chamber and draw bolt retraction (illustrated) as standard. Gland packing material is standardly supplied as non-asbestos graphite ribbon. Teflon is available. Please specify at time of order. Geared retraction - optional (see page 8).

For isolation valve details - see page 7.

#### MAXIMUM PRESSURE / TEMPERATURE

With standard ball valve 40 bar and 200°C  
With standard gate valve 40 bar and 450°C  
(Temperature is at valve)

† For liquid flow applications where there is a possibility of process pulsations or intermittent excessive flow velocity, the end-support model should always be selected for pipe sizes over 250mm internal diameter.

\*with end support

BASIC MODEL	D (mm)	FITS PIPE SIZES (mm)	STANDARD FLANGE SIZE
H611	13	50 - 100	1" (DN25)
H711†	25	100 - 1800	1½" (DN40)
H712*	25	300 - 3000	1½" (DN40)
H811†	60	300 - 2000	3" (DN80)
H812*	60	600 - 3000	3" (DN80)

other sizes available

Supplied with isolation valve and pressure chamber, and draw bolt retraction assembly and without flanged pipe fitting or stud bolts and gasket (Available as accessories - page 8). Gland packing material is standardly supplied as non-asbestos graphite ribbon. Teflon is available. Please specify at time of order. Geared retraction - Optional (see page 8). For isolation valve details - see page 7.

#### MAXIMUM PRESSURE / TEMPERATURE

With standard ball valve 100 bar and 200°C  
With standard gate valve 100 bar and 450°C  
(Temperature is at valve)

† For liquid flow applications where there is a possibility of process pulsations or intermittent excessive flow velocity, the end-support model should always be selected for pipe sizes over 600mm internal diameter.

\*with end support

**FOR VERTICAL PIPE INSTALLATIONS, SPECIFY OPTION 'VS' - SEE PAGE 12**

# WITHDRAWABLE TYPES (HOT TAP)

## MODEL CODING

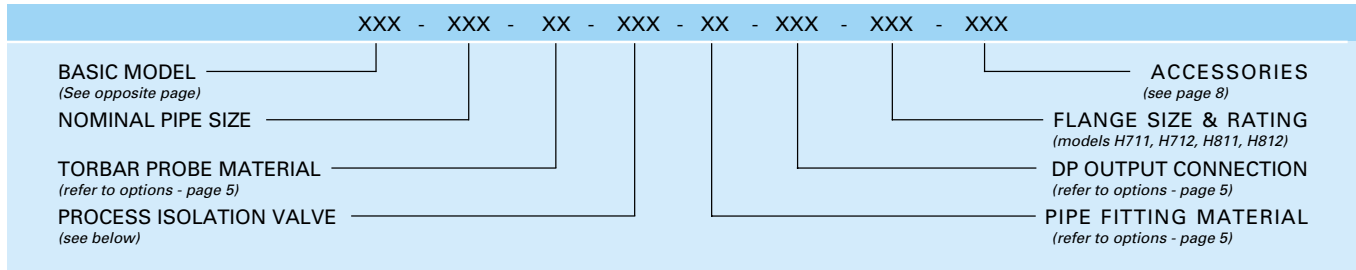

### PROCESS ISOLATION VALVES

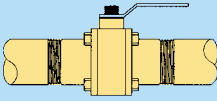
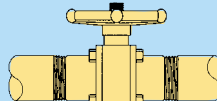
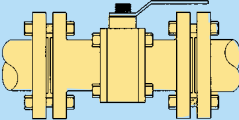
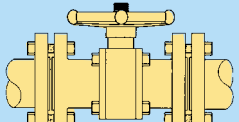
VALVE TYPE	TORBAR MODEL	VALVE SIZE	CODE (* IS MATERIAL SEE BELOW)	MAXIMUM TEMPERATURE AT VALVE
<b>Threaded Ball</b>  	L601	¾" BSPT	5B*	200°C
	L701 L702 H701 H702	1¼" BSPT	7B*	200°C
<b>Threaded Gate</b>  	L701 L702 H701 H702	1¼" BSPT	7G*	450°C
<b>Flanged Ball</b>  	H611	1"	4B*	200°C
	H711	1½"	8B*	200°C
	H712	2"	6B*	200°C
	H811 H812	3"	9B*	200°C
<b>Flanged Gate</b>  	H611	1"	4G*	450°C
	H711	1½"	8G*	450°C
	H712	2"	6G*	450°C
	H811 H812	3"	9G*	450°C

Code \* defines valve material

**316SS - (S) CARBON STEEL - (C) MONEL - (M) FOR OTHER MATERIAL SPECIFY (EXAMPLE: 7GC IS 1¼" BSPT GATE VALVE IN CARBON STEEL). WHEN VALVE IS SUPPLIED BY PURCHASER, WHOLE CODE IS: XXX.**

# ACCESSORIES

DESCRIPTION	MODELS	ILLUSTRATION	CODE
Vertical Pipe Installation	301, 311, 401, 402, 411, 412, 511, 512, L601, L701, L702, H701, H702, H711, H712, H811, H812		VS
	121, 122, 123		
Head for Direct Mounting of Valve Manifold or Transmitter	301, 311, 401, 402, 411, 412, 511, 512, L601, L701, L702, H701, H702, H711, H712, H811, H812		DM
Direct Mounting Head fitted with 3 or 5 Valve Manifold	301, 311, 401, 402, 411, 412, 511, 512, L601, L701, L702, H701, H702, H711, H712, H811, H812		3VDM (3 VALVE) 5VDM (5 VALVE)
Head with integral Valve Manifold (3 or 5) for fitting of transmitter by others. Transmitter fitted by TFL refer to TRIBAR, see page 16	301, 311, 401, 402, 411, 412, 511, 512, L601, L701, L702, H701, H702, H711, H712, H811, H812		DM3V DM5V
PT100 Temperature Element fitted through TORBAR head. For Hazardous Area Installations specify certification required	401, 402, 411, 412, 511, 512, L601, L701, L702, H701, H702, H711, H712, H811, H812		RTB Without Transmitter RTT With Transmitter
PT100 Temperature Element fitted through TORBAR neck. For Hazardous Area Installations specify certification required	401, 402, 411, 412, 511, 512, L601, L701, L702, H701, H702, H711, H712, H811, H812	 When specified with DM3V Head and integral DP Transmitter, refer to TRIBAR on page 16	NRTB Without Transmitter NRTT With Transmitter
Flanged Pipe Fittings (Stand-Off). Material is specified by "Pipe Fitting Material" in Model Number. Type, Size & Rating is specified with Model Number	311, 411, 412, 511, 512, H711, H712, H811, H812	 Note: Length "SO" is given on page 9	FS
Stud Bolts, Nuts & Gasket	311, 411, 412, 511, 512, H711, H712, H811, H812	<b>Standard Materials</b> Stud, Bolts & Nuts: A193-B7/A 194-2H Gasket: Asbestos Free Glass/Aramid Fibre/Nitrile	SBG
		<b>For Other Gasket Material: Specify</b>	SBGS
Thin duct wall Mounting Plate. Recommended for large ducts with wall thickness of less than 2mm	301, 401, 402, L601, L701, L702, H701, H702	 	DF
Gear Retraction Assembly (Material: 316L Stainless Steel)	H701, H702, H711, H712, H811, H812		GR
Bi-Directional Probe	401, 402, 411, 412, 511, 512, L601, L701, L702, H701, H702, H711, H712, H811		BW

# TORBAR DIMENSIONAL INFORMATION

## FLANGED STANDOFF DIMENSIONS (ACCESSORY FS) OVERALL LENGTH SO (mm)

ANSI CLASS	SIZE			
	1"	1½"	2"	3"
150	83	95	102	118
300	89	100	108	127
600	95	109	117	137
900	106	122	146	156
1500	106	122	146	171
2500	122	150	171	222

DIN CLASS	SIZE			
	DN25	DN40	DN50	DN80
PN10	67	78	86	98
PN16	67	78	86	98
PN25	67	78	86	98
PN40	67	78	86	106
PN50	89	101	108	127
PN110	89	103	111	131
PN150	100	116	140	150
PN260	100	116	140	165

## FLANGED ISOLATION VALVE OVERALL LENGTH LV (mm)

SIZE	ANSI CLASS			
	150	300	600	1500
1"	127	165	216	254
1½"	165	191	241	305
2"	178	216	308	368
3"	203	283	375	381

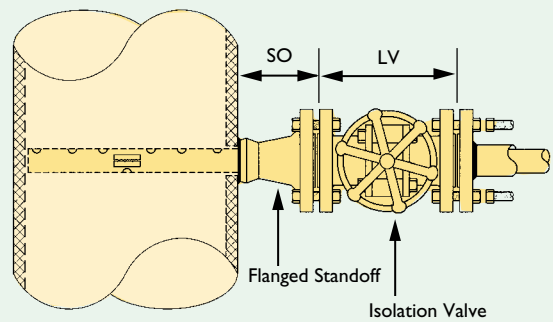

## WITHDRAWABLE TYPES (HOT-TAPS) INSERTED AND RETRACTED LENGTHS (ALLOWS 5% FOR TOLERANCING) (mm)

<b>L601</b>	Inserted	ID + 236
	Retracted	INSERTED + ID + WALL + 211
<b>L701</b>	Inserted	ID + 346
	Retracted	INSERTED + ID + WALL + 208
<b>L702</b>	Inserted	ID + WALL + 371
	Retracted	INSERTED + ID + WALL + 233
<b>H701</b>	Inserted	ID + 493
	Retracted	INSERTED + ID + 355
<b>H702</b>	Inserted	ID + WALL + 518
	Retracted	INSERTED + ID + WALL + 380
<b>H711</b>	Inserted	ID + WALL + 2(SO + LV) + 340
	Retracted	INSERTED + ID + WALL + SO + LV
<b>H712</b>	Inserted	ID + 2(WALL + SO + LV) + 380
	Retracted	INSERTED + ID + WALL + SO + LV + 40
<b>H811</b>	Inserted	ID + WALL + 2(SO + LV) + 355
	Retracted	INSERTED + ID + WALL + SO + LV
<b>H812</b>	Inserted	ID + 2(WALL + SO + LV) + 419
	Retracted	INSERTED + ID + 2x WALL + SO + LV + 60

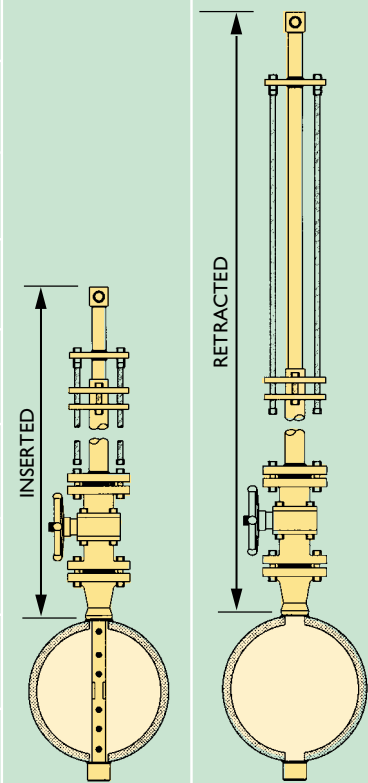

FOR GEARED RETRACTION UNITS (ACCESSORY GR) ADD 100mm TO ABOVE DIMENSIONS

# INDEPENDENT TEST REPORTS

A range of TORBAR models and sizes have been tested at Independent Flow Laboratories to determine the accuracy and repeatability of measurement. Those test were conducted in both Air and Water.

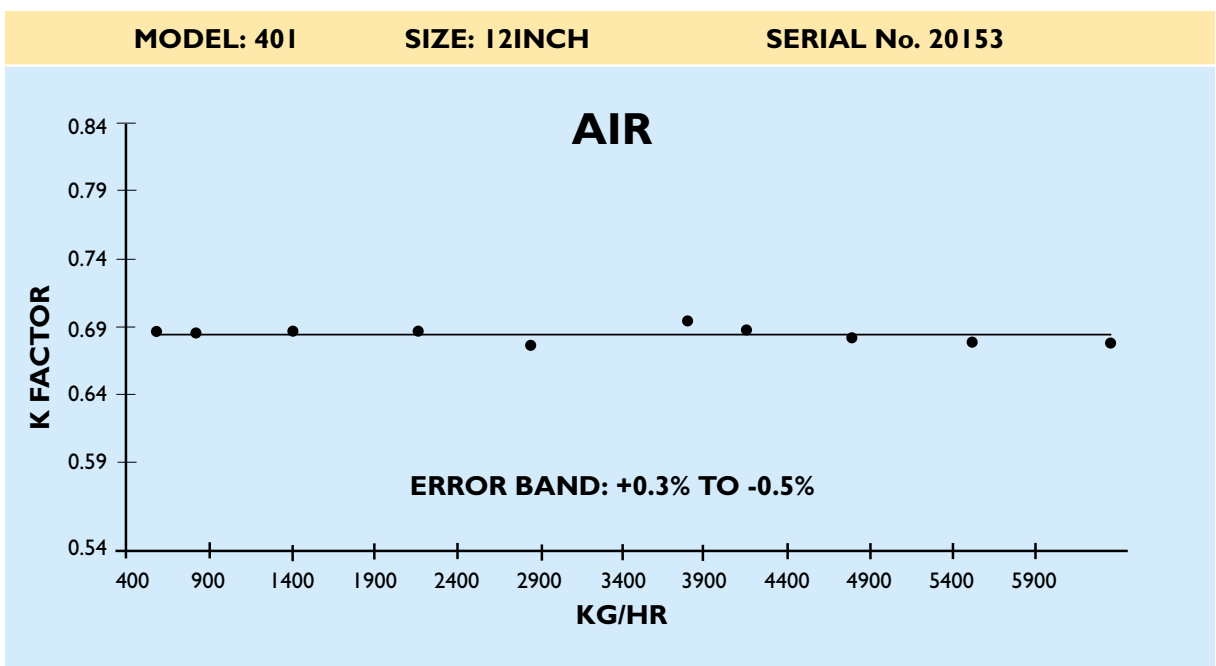
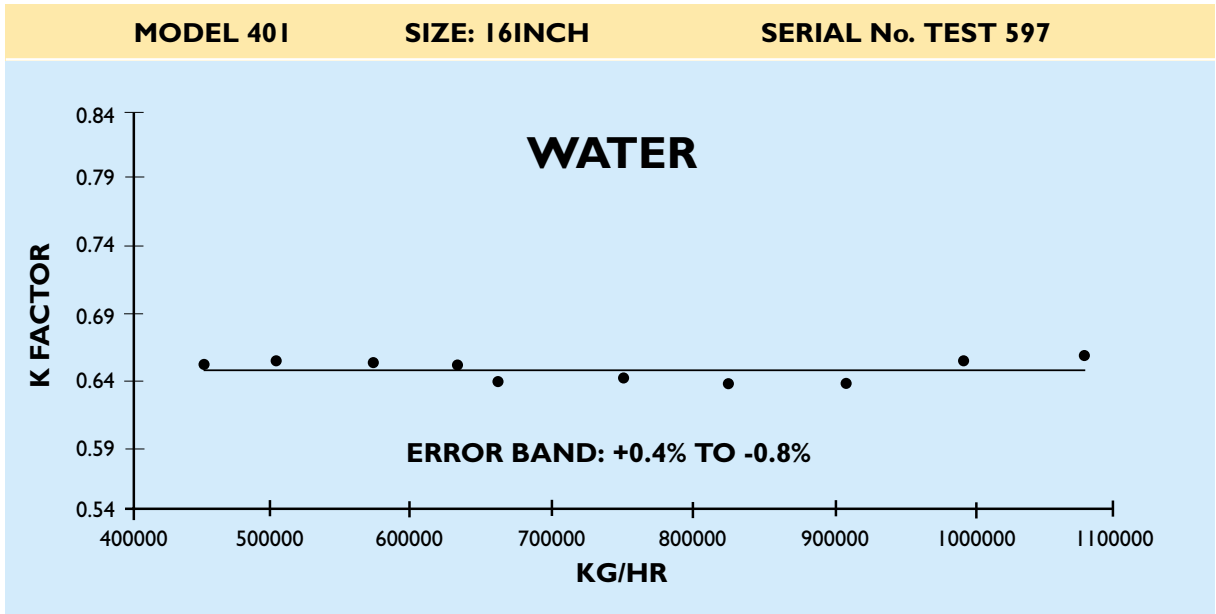

Full details of the test results above and of those shown in the table below are available on request.

TEST FLUID	MODEL	SIZE	SERIAL NUMBER	ERROR BAND
WATER	123	2"	TEST 197	+0.2 TO -0.43%
WATER	301	4"	TEST 297	+1 TO -1%
AIR	401	6"	TEST 397	+0.1 TO -0.5%
AIR	402	18"	20186	+0.6 TO -0.5%
WATER	411	24"	TEST 697	+0.3 TO -0.4%

# DIFFERENTIAL PRESSURE CALCULATIONS AND RESONANCE FREQUENCY CHECK

## FLOW TO DP

### LIQUIDS (Volumetric)

$$DP = \left[ \frac{QA \times \sqrt{D}}{K \times A \times 4.6285} \right]^2 \text{ mbar}$$

### GASES (Volumetric)

$$DP = \left[ \frac{S \times (Tf + 273)}{Pf} \right] \left[ \frac{QB}{K \times A \times 66.839} \right]^2 \text{ mbar}$$

### LIQUIDS / GASES / STEAM (Mass)

$$DP = \left[ \frac{QC}{K \times A \times \sqrt{D} \times 4.6285} \right]^2 \text{ mbar}$$

### SYMBOLS & UNITS

- QA** = Flow (m<sup>3</sup>/hr)
- QB** = Flow (Nm<sup>3</sup>/hr) at 0°C, 1 atm (1.013 bar)
- QC** = Flow (kg/hr)
- S** = Specific Gravity (Air = 1)
- D** = Density at actual conditions (kg/m<sup>3</sup>)  
Base Density of water at 4°C = 999.972 kg/m<sup>3</sup>  
Density of water at 15.55°C = 999.074 kg/m<sup>3</sup>  
Base Density of Air at 0°C  
1 ATMOS (1.013 bar) = 1.292 kg/m<sup>3</sup>
- A** = Pipe internal X-Section Area (cm<sup>2</sup>)
- Tf** = Actual Temperature (°C)
- Pf** = Actual Pressure (bar Absolute)
- K** = Torbar Co-efficient (see table)

Copies of the derivations of these formulae are available on request.

THE CALCULATION SOFTWARE (TORWIN) IS AVAILABLE FREE OF CHARGE BY POST OR E-MAIL.

## TORBAR CO-EFFICIENT K

		MODEL NUMBER					
PIPE SIZE (Internal diameter)	(mms)	301	601	401	402	511	512
		311		411	412	811	812
				701	702		
				711	712		
50	0.6483						
75	0.7027						
100	0.7497	0.6174					
150	0.7671	0.6505					
200		0.6647					
250		0.6794	0.6876				
300		0.6941	0.7024				
350		0.7160	0.7303				
400		0.7380	0.7564				
450		0.7402	0.7699				
600		0.7468	0.7815				
900		0.7473	0.7847				
1200		0.7475	0.7849				
1500		0.7476	0.7850				
1800	and above	0.7476	0.7850				

FOR SIZES NOT SHOWN ABOVE, DETERMINE K BY EXTRAPOLATION

For Models 121, 122, 123 (all sizes) K = 1

IT IS IMPORTANT THAT THE ANSWERS FROM THESE EQUATIONS ARE VERIFIED WITH THE FACTORY OR TORBAR ACCREDITED SUPPLIER BEFORE USE WITH YOUR SYSTEM

## DP TO FLOW

### LIQUIDS (Volumetric)

$$\text{Flow}(Q) = \sqrt{DP} \times \left[ \frac{K \times A \times 4.6285}{\sqrt{D}} \right] \text{ m}^3/\text{hr}$$

### GASES (Volumetric)

$$\text{Flow}(Q) = \sqrt{DP} \times \left[ \frac{K \times A \times \sqrt{(Tf+273)}}{\sqrt{S \times 4.0323 \times Pf}} \right] \text{ Am}^3/\text{hr}$$

(Actual conditions)  
or

$$\text{Flow}(Q) = \sqrt{DP} \times \left[ \frac{K \times A \times 66.839 \times \sqrt{Pf}}{\sqrt{S \times (Tf+273)}} \right] \text{ Nm}^3/\text{hr}$$

(Normal conditions)

### LIQUIDS / GASES / STEAM (Mass)

$$\text{Flow}(Q) = \sqrt{DP} \times (K \times A \times \sqrt{D} \times 4.6285) \text{ kg/hr}$$

### SYMBOLS & UNITS

- DP** Differential Pressure (mbar)
  - S** Specific Gravity (Air = 1)
  - D** Density at Actual Conditions (kg/m<sup>3</sup>)  
Base Density of Water at 4°C 999.972 kg/m<sup>3</sup>  
Density of Water at 15.55°C 999.074 kg/m<sup>3</sup>  
Density of Air at 0°C 1.292 kg/m<sup>3</sup>
  - A** Pipe Internal x-section Area (cm<sup>2</sup>)
  - Tf** Actual Temperature (°C)
  - Pf** Actual Pressure (Bar A) (Absolute)
  - K** TORBAR Co-efficient (see Table)
- Normal Conditions 0°C, 1 Atmosphere (1.013 bar)

STATEMENT OF ACCURACY:

The calculated differential pressure will lie within an uncertainty band of +/- 1% with 95% confidence if the TORBAR is installed strictly in accordance with the published Installation Instructions. For applications which do not conform to those instructions, it is recommended that an on site calibration is performed in order to achieve the optimum accuracy.

## RESONANCE FREQUENCY CHECK

This check is not necessary for LIQUID FLOWS, because the maximum allowable DP is reached before resonance occurs (see table opposite) or Models 121, 122, and 123. For Gas and Vapour flows a Resonance Frequency Check MUST be made. Equations have been derived for the various TORBAR models to determine LOW and HIGH critical velocities (VL and VH) which define the narrow resonance band of velocities which should be outside the continuous operating flow range of the TORBAR. The table below lists those equations to calculate the VL and VH. If the calculation shows VL to VH to be within the continuous operating flow range, then an alternative, suitable model of TORBAR should be selected to give acceptable values of VL and VH. Always check that the maximum flow DP is less than the 'Maximum Allowable DP' as shown in the opposite table.

TORBAR MODEL	CRITICAL VELOCITIES		UNSUPPORTED LENGTH L (METRES) (see below)
	VL (M/SEC)	VH (M/SEC)	
301	0.472 ÷ L <sup>2</sup>	0.728 ÷ L <sup>2</sup>	ID + WALL + 0.05
311	0.472 ÷ L <sup>2</sup>	0.728 ÷ L <sup>2</sup>	ID + WALL + SO
L601	0.472 ÷ L <sup>2</sup>	0.728 ÷ L <sup>2</sup>	ID + WALL + 0.02
401	1.843 ÷ L <sup>2</sup>	2.840 ÷ L <sup>2</sup>	ID + WALL + 0.08
402	8.08 ÷ L <sup>2</sup>	12.44 ÷ L <sup>2</sup>	ID + 2 x WALL + 0.115
411	1.843 ÷ L <sup>2</sup>	2.840 ÷ L <sup>2</sup>	ID + WALL + SO
412	8.08 ÷ L <sup>2</sup>	12.44 ÷ L <sup>2</sup>	ID + 2 x WALL + SO + 0.05
L701	1.843 ÷ L <sup>2</sup>	2.840 ÷ L <sup>2</sup>	ID + WALL + 0.05
L702	8.08 ÷ L <sup>2</sup>	12.44 ÷ L <sup>2</sup>	ID + 2 x WALL + 0.10
H701	1.843 ÷ L <sup>2</sup>	2.840 ÷ L <sup>2</sup>	ID + WALL + 0.05
H702	8.08 ÷ L <sup>2</sup>	12.44 ÷ L <sup>2</sup>	ID + 2 x WALL + 0.10
H711	1.843 ÷ L <sup>2</sup>	2.840 ÷ L <sup>2</sup>	ID + WALL + SO + VV + 0.05
H712	8.08 ÷ L <sup>2</sup>	12.44 ÷ L <sup>2</sup>	ID + 2 x WALL + SO + VV + 0.10
511	10.88 ÷ L <sup>2</sup>	16.766 ÷ L <sup>2</sup>	ID + WALL + SO
512	47.65 ÷ L <sup>2</sup>	73.43 ÷ L <sup>2</sup>	ID + 2 x WALL + SO + 0.08
H811	10.88 ÷ L <sup>2</sup>	16.766 ÷ L <sup>2</sup>	ID + WALL + SO + VV + 0.05
H812	47.65 ÷ L <sup>2</sup>	73.43 ÷ L <sup>2</sup>	ID + 2 x WALL + SO + VV + 0.13

- L** = UNSUPPORTED LENGTH (METRES)
- ID** = PIPE INTERNAL DIAMETER (METRES)
- WALL** = PIPE WALL THICKNESS (METRES)
- SO** = OVERALL LENGTH OF FLANGED PIPE FITTING (METRES) (See page 9)
- VV** = OVERALL LENGTH OF ISOLATION VALVE (METRES) (See page 9)

THE ABOVE EQUATIONS ARE DERIVED FROM TORBAR RESONANCE FREQUENCY DATA AND CALCULATIONS. FULL DETAILS ARE AVAILABLE ON REQUEST.

## MAXIMUM ALLOWABLE DP

Depending on the model and size of TORBAR there is a maximum figure of Differential Pressure above which the TORBAR should NOT be used due to the imposition of excessive mechanical stresses. Check the table below to ensure that the application is suitable. If the calculated DP exceeds the maximum shown below, then select an other appropriate model to suit the application. For Bi-Directional configurations (accessory code BVV), use 50% of the figures in this table.

FOR LIQUID FLOW APPLICATIONS WHERE THERE IS A POSSIBILITY OF PROCESS PULSATIONS OR INTERMITTENT EXCESSIVE FLOW VELOCITY, THEN THE END-SUPPORT MODELS SHOULD ALWAYS BE SELECTED FOR PIPE SIZES OVER 250mm DIAMETER (400 AND 700 SERIES) AND 600mm (500 AND 800 SERIES).

PIPE SIZE (Internal Dia.)	TORBAR BASE MODEL NUMBER *								
	301	311	401	411	402	412	511	512	
	601		701	711	702	712	811	812	
	611								
(ins)	(mms)	Maximum allowable DP in mbar							
2	50	6250							
3	75	2790							
4	100	1565	5100						
6	150	695	2285						
8	200		1285						
10	250		820	3250	3400				
12	300		570	2250	2350				
14	350		415	1680	1725				
16	400		320	1285	1335				
18	450		250	1015	1055	4225			
24	600		140	570	590	2375			
36	900		50	250	265	1055			
48	1200		30	140	145	590			
60	1500		20	90	90	380			
72	1800		10	60	65	265			

Above 1800 mm - consult factory

FOR SIZES NOT SHOWN ABOVE DETERMINE MAXIMUM ALLOWABLE DP BY EXTRAPOLATION

\* For models 121, 122, 123 (all sizes) Maximum DP value is 2500 mbar.

THE ABOVE FIGURES ARE THEORETICALLY DERIVED AND INCLUDE A X10 SAFETY FACTOR OVER AND ABOVE BASIC STANDARDS AND SPECIFICATION. FULL THEORETICAL DATA IS AVAILABLE ON REQUEST.

# INSTALLATION & LOCATION

## Recommended Upstream and Downstream Distances

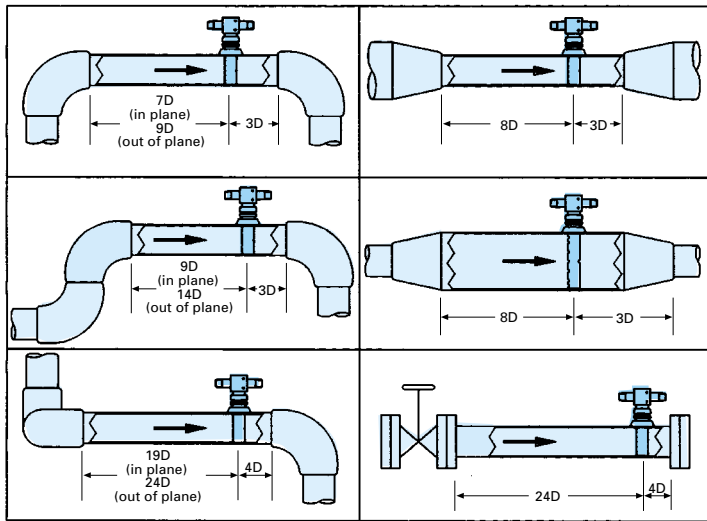

Correct location of the **TORBAR** in the piping system is important in order to optimise performance. Flow that is disturbed by upstream configurations such as elbows, T's and valves may have an adverse effect on accuracy unless the **TORBAR** is located at recommended positions shown in the table opposite. The diagrams illustrate the distances in multiples of pipe bore 'D' between the **TORBAR** and the upstream and downstream disturbances. If the **TORBAR** is fitted within distances less than those shown, then absolute accuracy may be downgraded BUT repeatability of measurement will still be excellent due to inherent averaging characteristics.

Where it is not possible to provide the specified distances and maximum accuracy is required, the use of a flow straightening spool piece allows for shorter distances.

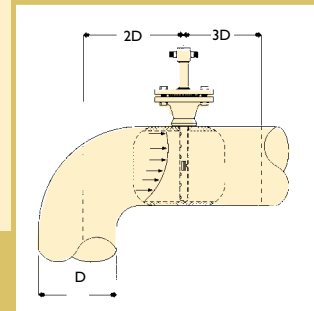

### ELBOW INSTALLATION (Right)

The **TORBAR** can be installed 2 diameters downstream of a 90° elbow at the exit of the elbow to give an accuracy of +/-3% to +/-5%.

## Orientation in Pipe

The **TORBAR** must be installed at right angles to the pipe run and across a pipe diameter within the tolerances shown in the diagrams opposite.

To avoid 'noisy' signal outputs, do not locate the **TORBAR** in a pulsating flow. A vibrating pipe can also distort the output signal and affect the structural limits of the **TORBAR**. This limitation particularly applies to the integrally mounted transmitter option DM3V and to the TRIBAR configuration

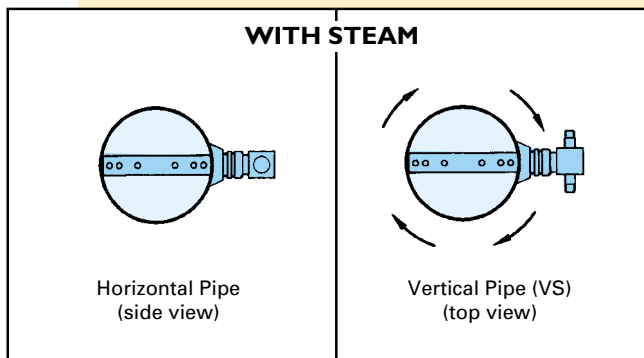
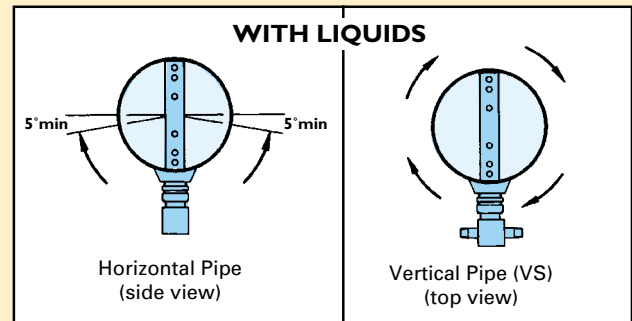
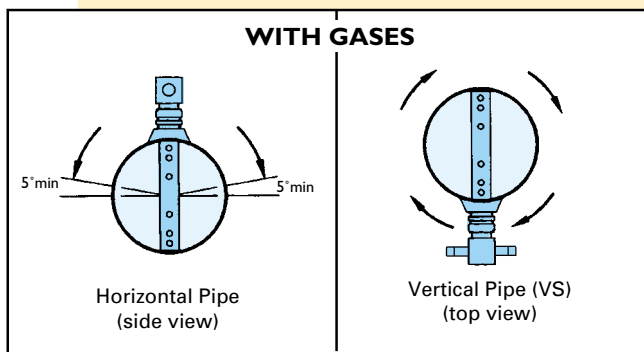
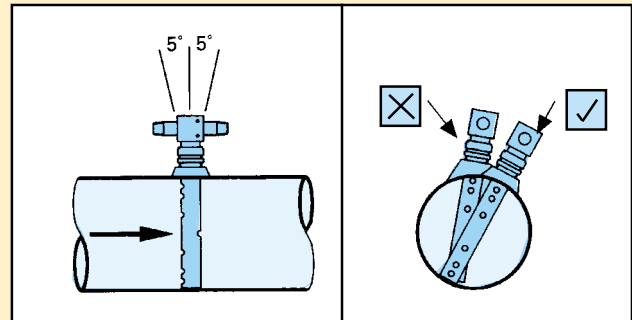

For vertical pipe applications, the 'head' of the **TORBAR** is repositioned to ensure that DP connections are at the same vertical level. This is option VS. **IT IS NECESSARY TO SPECIFY THIS OPTION WHEN ORDERING THE TORBAR.**

**IT IS ESSENTIAL THAT IN ALL STEAM INSTALLATIONS THE ENTIRE TORBAR HEAD AND FITTING ASSEMBLY ARE WELL LAGGED TO PREVENT THE FORMATION OF CONDENSATE IN THE TORBAR HEAD. THE TORBAR WILL NOT FUNCTION CORRECTLY WITH CONDENSATE IN THE HEAD. FILLING T'S OR CONDENSATE POTS SHOULD BE FITTED AS APPROPRIATE.**

Before installation or removal of a **TORBAR** it is imperative that careful reference is made to the appropriate installation instructions that are supplied with each **TORBAR** shipment. The installation instructions are also available separately on request.

## TYPICAL HOOK-UP DIAGRAMS

### VOLUMETRIC flow measurement with TORBAR Alternative output configurations

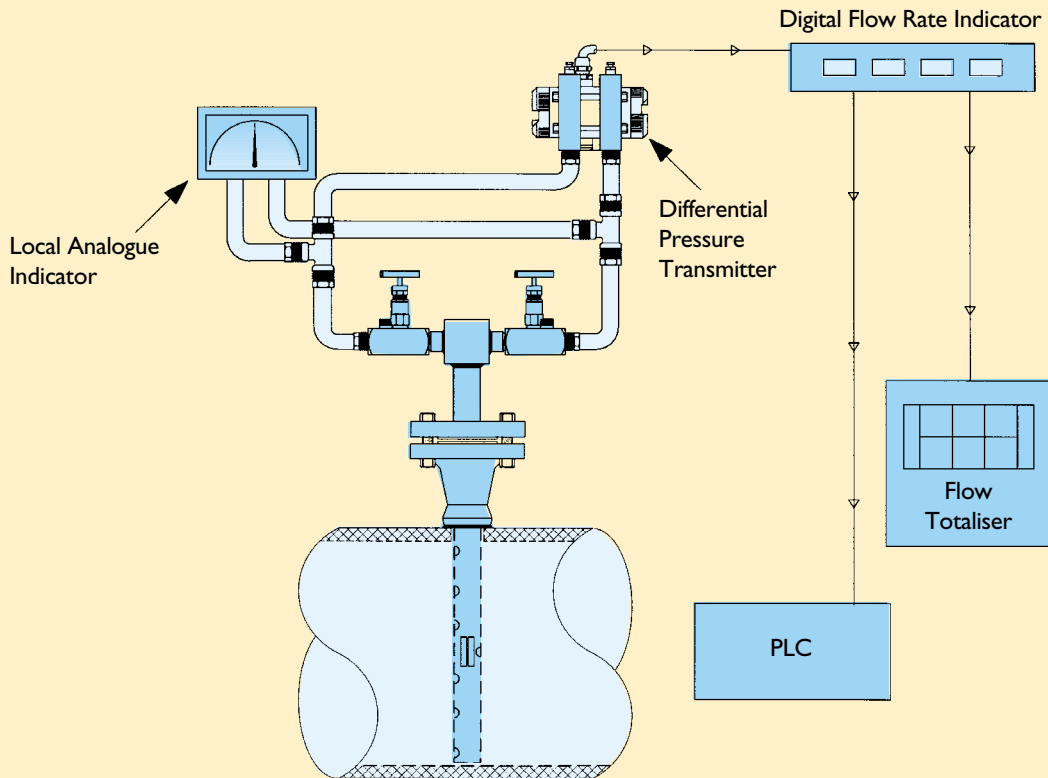

Abbreviated details of the **TORBAR** installation are shown on page 12, but the Installation and Operating Instructions manual should be referred to before making a final installation. Copies are available on request.

### MASS FLOW measurement with TRIBAR Using remote flow Computer

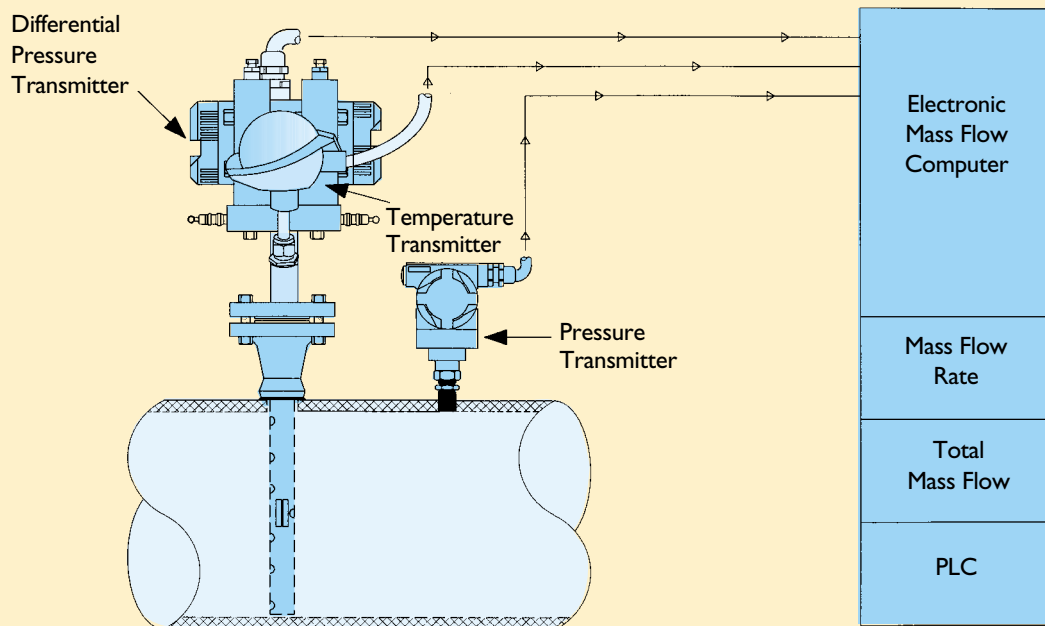

The above diagram shows how the **TRIBAR** can be used to complete a **MASS FLOW LOOP**. Alternatively, the **MASS TRIBAR** can be considered as a totally integrated package.

• Full details of the **TRIBAR** are on pages 16 & 17 • Full details of the **MASS TRIBAR** are on pages 18 & 19

## APPLICATIONS

Thousands of **TORBARS** have been successfully used on a large variety of flow applications throughout the world by many different industries, such as:

- OIL PRODUCTION (ONSHORE, OFFSHORE)
- OIL REFINING
- CHEMICAL
- PHARMACEUTICAL
- POWER GENERATION
- BUILDING SERVICES
- H V A C
- NUCLEAR
- FOOD
- WATER DISTRIBUTION
- WATER TREATMENT
- EFFLUENT TREATMENT
- GAS PROCESSING
- GAS TRANSMISSION
- etc. etc.



Applications where **TORBARS** have been used successfully were for the flow measurement of:

- NATURAL GAS
- FLUE GAS
- NITROGEN GAS
- HYDROCARBON GAS
- METHANE GAS
- COMBUSTION GAS
- SOUR GAS
- EXHAUST GAS
- COKE OVEN GAS
- CARBON DIOXIDE GAS
- PETROL VAPOUR
- VENTILATION AIR
- COMPRESSED AIR
- HOT AIR
- SOLVENT LADEN AIR
- SATURATED AIR
- .....
- SATURATED STEAM
- SUPERHEATED STEAM
- SEA WATER
- COOLING WATER
- RIVER WATER
- WASTE WATER
- POTABLE WATER
- LIQUID OXYGEN
- CRUDE OIL
- NITRIC ACID
- RED WINE
- LIQUID PETROLEUM
- and many other...

## COST SAVINGS TORBAR v ORIFICE PLATE

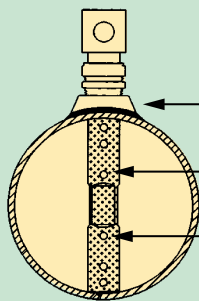

### TORBAR

- Low Installation Cost
- Low Pressure Loss - LOW ENERGY CONSUMPTION
- Long Term Accuracy - LOW MAINTENANCE COST

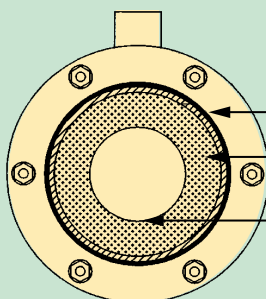

### ORIFICE-PLATE

- High Installation Cost
- High Pressure Loss - HIGH ENERGY CONSUMPTION
- Short Term Accuracy - HIGH MAINTENANCE COST

## SPECIAL CONFIGURATIONS

The **TORBAR** and **TRIBAR** flow meters are well suited for special configurations to satisfy customer applications and specifications. Qualified engineering staff and sophisticated computer facilities enable the rapid and accurate translation of the customer requirements into a reliable product.

On this page are shown a few examples of this engineering capability.



A TORBAR MACHINED FROM SOLID DUPLEX MATERIAL BAR WITH SPECIAL TECKLOK FLANGE RATED AT 455 BAR AND FITTED WITH DOUBLE BLOCK AND BLEED VALVES



CONTINUOUS AIR PURGE SYSTEM FOR USE WITH A TORBAR MEASURING CONTAMINATED GAS FLOWS

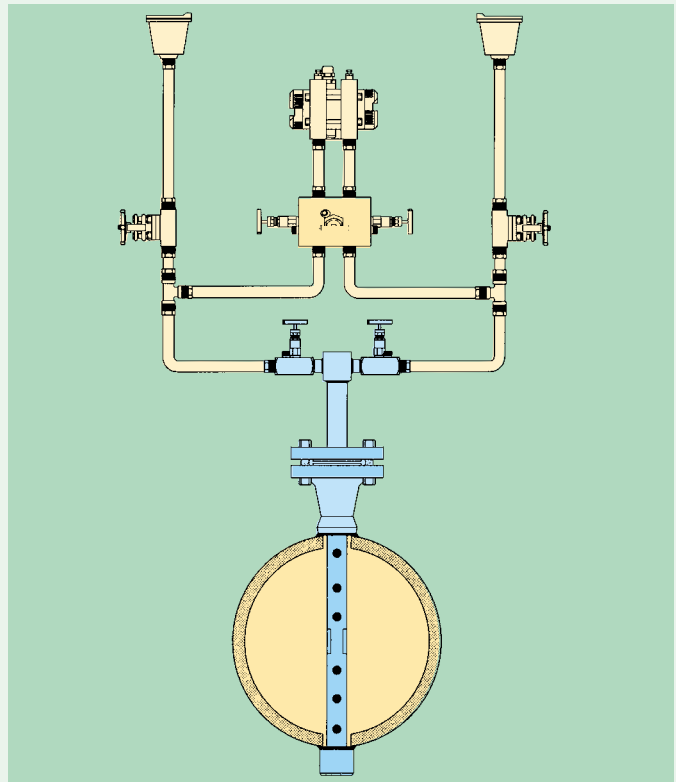

AUTOMATIC AIR VENTING PACKAGE FITTED TO TORBAR IN ORDER TO REMOVE THE AIR WHEN THE TORBAR IS INSTALLED VERTICALLY DOWNWARDS



A TRIBAR WITH INTEGRAL TEMPERATURE TRANSMITTER AND MOUNTED ON TO AN ELEMENT MANUFACTURED FROM SUPER DUPLEX.

# TOTAL METER PACKAGE

## DESCRIPTION

The **TRIBAR** is the established and proven flowmeter from Torbar Flowmeters Ltd, the company that developed and perfected the **TORBAR** technology, and Siemens a world leader in Differential Pressure measurement.

The **TRIBAR** is an accurate insertion flowmeter comprising of an integral 3 valve manifold and Siemens Sitrans P Transmitter connected to a **TORBAR** averaging insertion element.

The **TRIBAR** is suitable for the flow measurement of most liquids and gases at process temperatures of less than 160°C. It is not recommended for steam flow due to the temperature specification of the transmitter. This restriction of use applies to all flowmeters of this type.

For steam flow and other applications which fall outside of the **TRIBAR** specifications, the transmitter and manifold should be mounted remotely from the **TORBAR** as shown on page 13. Please contact TFL or agent for details.

The **TRIBAR** concept provides several economic and operational advantages.

- SIMPLE ONE OR TWO HOLE INSTALLATION
- COMPACT INSTRUCTION
- LOW PRESSURE LOSS/LOW OPERATING COSTS
- COMPETITIVE PRICING
- ZERO TRANSMISSION LAGS

The **TRIBAR** is available **WITHOUT** the transmitter which can be fitted by the customer (or TFL agent). For this optional arrangement specify a standard **TORBAR** with DM3V (integral manifold) option (see page 8). Also specify the manufacturer and type of transmitter to be fitted.

# TRIBAR



## MODEL CODING

T XXX - XXX - SS - XX - XX - XXX - XXX - XXX

**TORBAR MODELS**  
PERMANENT  
Page 4

**HOT TAP**  
Page 6

**PIPE SIZE**

**TORBAR MATERIAL**  
(316L SS)

**ISOLATION VALVE**  
Page 7  
Hot Tap models only

**TRANSMITTER TYPE**

**ACCESSORIES**  
Pages 8

**FLANGE SIZE & RATING**  
Models 311, 411, 412  
H711, H712

**PIPE FITTING MATERIAL**  
Page 5

## TEMPERATURE MEASUREMENT

The **TRIBAR** can be supplied with an RTD element with or without a Transmitter. Refer to page 8 code NRTB or NRTT.

Also see page 13 for typical application.

## INSTALLATION & LOCATION

For basic information about the installation and location of the **TRIBAR** refer to page 12.

## SPECIFICATIONS AND OPTIONS

- FLOWMETER TYPE: Insertion
- REFERENCE ACCURACY: +/- 1.25%
- REPEATABILITY OF MEASUREMENT: 0.1%
- FLOW TURNDOWN: 10:1
- PIPE SIZES: 5 to 4000mm
- INTEGRAL MANIFOLD: 3 valve-stainless steel
- PROCESS MOUNTING: Compression or flanged
- INSTALLATION OPTION:  
By Hot-tapping under pressure
- WETTED PARTS: 316 stainless steel
- MAXIMUM PRESSURE:  
160 Bar (420 bar optional)
- MAXIMUM TEMPERATURE: 160°C at process

# TRIBAR

## DP TRANSMITTER PROGRAMMABLE AND SMART

- SUPPLY: 11V - 45 VDC (AC optional)
- OUTPUT: 4 to 20 mA with Hart 5.1 superimposed (optional PROFIBUS PA)
- MINIMUM DP RANGE: 0-1 mbar to 0-20 mbar
- CERTIFICATION: Intrinsically Safe Exiallc T4/T5/T6
- ELECTRONICS HOUSING:  
Coated die-cast Aluminium (option stainless steel)
- INGRESS PROTECTION: IP65 (option IP68)
- CABLE ENTRY: M20 X 1.5 cable gland
- CALIBRATION CERTIFICATE: Available as option
- NACE CERTIFICATE: Available as option

### EASIER ON-SITE COMMISSIONING WITH CURRENT GENERATOR OUTPUTS (3.6, 4, 12, 20mA)

SIMPLE PUSH BUTTON CALIBRATION WHICH CAN BE USED IN HAZARDOUS AREAS

FULL WARRANTY COVER BY TFL SUPPORTED BY SIEMENS OFFICES WORLDWIDE

### FLOW TURN DOWN

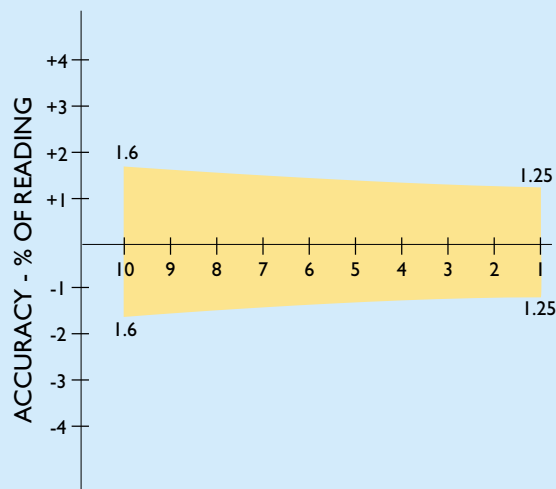

### PRESSURE LOSS

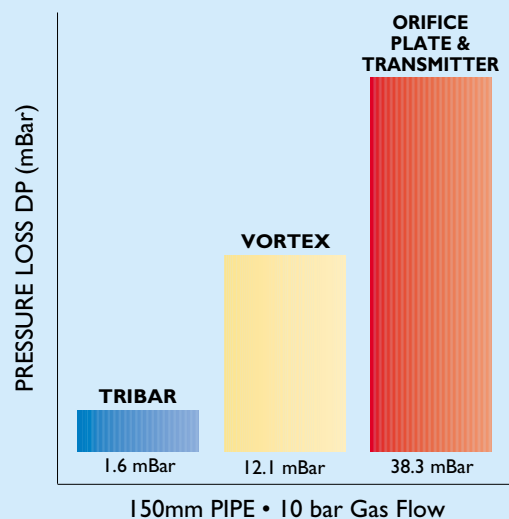

# COMPENSATED MASS FLOWMETER

## DESCRIPTION

The **MASS TRIBAR** is an insertion flowmeter comprising an integral valve manifold a PT100 temperature element and a Smart Multivariable Transmitter attached to a **TORBAR** averaging flow element.

The **MASS TRIBAR** measures pressure, temperature and differential pressure directly from the **TORBAR** and computes the compensated mass flow within the MV transmitter by automatically compensating for fluctuations in temperature and pressure.

The **MASS TRIBAR** is ideally suited for the flow measurement of liquids and gases and the totally integrated concept provides several direct advantages.

- AVERAGED FLOW PROFILE MEASUREMENT
- SIMPLE ONE OR TWO HOLE INSTALLATION
- COMPACT INTEGRAL CONSTRUCTION
- RTD EASILY REMOVABLE FOR MAINTAINANCE
- ZERO TRANSMISSION LAGS
- LOW PRESSURE LOSS/LOW OPERATING COSTS
- SINGLE PRODUCT SOURCING

## METER CODING

MT XXX - XXX - SS - XX - XX - XXX - XXX - XXX

**TORBAR MODELS**  
Page 4, 6

**PIPE SIZE**

**TORBAR MATERIAL**  
316L SS

**ISOLATION VALVE**  
(Hot tap only)

**TRANSMITTER TYPE**

**ACCESSORIES**  
Pages 8

**FLANGE SIZE & RATING**  
Models: 411, 412  
H711, H712

**PIPE FITTING MATERIAL**  
Page 5

# MASS TRIBAR



## APPLICATION LIMITATION

For steam flow and other applications which fall outside of the **MASS TRIBAR** specifications, the multivariable transmitter and manifold should be mounted remotely. Please contact TFL or Agent for details of that arrangement.

## INSTALLATION & LOCATION

For the basic information about the installation and location of the **MASS TRIBAR** refer to page 12.

Refer to the MV Transmitter data sheet for the transmitter calibration and set-up information and procedures.

**PRESSURE - TEMPERATURE - FLOW**  
**THE MASS TRIBAR CAN DO IT ALL**

## COST SAVINGS

With the **MASS TRIBAR** configuration, you can expect substantially lower wiring costs, as well as much less capital spending on piping, manifolds, mounting, safety barriers and the like. With four measurements from one instrument you will be driving down the installed cost of flow compensation by as much as 60%. Also the MASS TRIBAR may totally eliminate the need for a mass flow computer and can free your control system from performing complex flow calculations. The compensated flow calculation is done right in the instrument before it sends data to your control room freeing up your automation system for other process control tasks.

Because it has been difficult and expensive to directly measure flow, most applications infer flow. Inferential flow calculations assume pressure and temperature remain constant, which is often extremely misleading and gives rise to large inaccuracies. **THIS TRANSLATES TO LOST PROFITS.** Accurate, reliable measurements of flow are essential to ensure your company meets customer quality demands, minimises expenses and increases your bottom line profitability.

# MASS TRIBAR

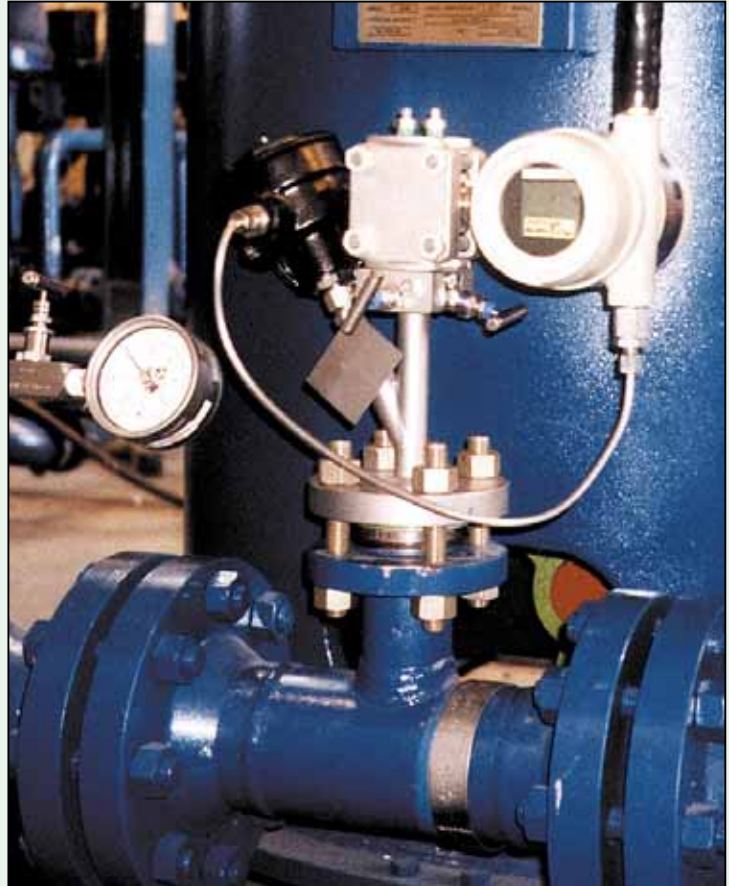

## SPECIFICATION

- ACCURACY: +/-1% FLOW +0.1% OF CALIBRATED SPAN
- REPEATABILITY OF MEASUREMENT: 0.2%
- FLOW RANGE TURNDOWN: 10 TO 1
- TEMPERATURE ELEMENT: RTD - 4 WIRE
- MAXIMUM PRESSURE: 400 Bar
- MAXIMUM TEMPERATURE AT MANIFOLD/TRANSMITTER FACE: 120°C
- MINIMUM TEMPERATURE AT MANIFOLD/TRANSMITTER FACE: -50°C
- AMBIENT TEMPERATURE RANGE: -40°C TO 85°C
- SYSTEM: 2 WIRE (DC 1 V - 45V) EXTERNAL POWER SUPPLY REQUIRED
- OUTPUT: 2 WIRE 4 TO 20 mA LINEAR TO MASS FLOW
- DIGITAL HART PROTOCOL AVAILABLE TO HOST WHICH CONFORMS TO THE HART PROTOCOL
- PRESSURE, TEMPERATURE AND DP VARIABLES ARE AVAILABLE THROUGH HART
- PROCESS INDICATOR: INTEGRAL. 2LINE. 6CHARACTER
- PROTECTION: IP67. EEXia I I CT4/T5/T6
- WETTED PARTS: 316L STAINLESS STEEL
- PIPE SIZES: 100mm TO 8000mm
- DIFFERENTIAL PRESSURE RANGES: 0.5/10mbar TO 1/100bar
- STABILITY: +/-0.1% URL FOR 12 MONTHS
- FOR MORE DETAILED SPECIFICATIONS REFER TO THE TRANSMITTER SPECIFICATION SHEET



Designed & Produced by Viccarì Wheels Ltd +44 (0)1273 244088 Leaflet: TOR10.2000



## TORBAR FLOWMETERS LTD

Unit 21, Star Road,  
Partridge Green,  
West Sussex. RH13 8RA  
United Kingdom

Telephone: +44(0)1403 711088  
Facsimile: +44(0)1403 711335  
e-mail: [info@torbar.co.uk](mailto:info@torbar.co.uk)  
Web: [www.torbar.co.uk](http://www.torbar.co.uk)

