

GWC Valve International



PROVEN TECHNOLOGY FOR INDIVIDUAL VALVE SOLUTIONS - WORLDWIDE



CAST STEEL VALVES

Pressure Class: 150 - 1500

Size Range: 2" - 60"

API Standard: 600 & 603

ASME B16.34



TABLE OF CONTENTS

Gate Valve Standard Features	4
Globe Valve Standard Features	6
Swing Check Valve Standard Features	8
Ordering Guide	9

CAST STEEL GATE VALVES

Class 150	10
Class 300	11
Class 600	11
Class 900	12
Class 1500	12

CAST STEEL GLOBE AND ANGLE VALVES

Class 150	13
Class 300	14
Class 600	14
Class 900	15
Class 1500	15

CAST STEEL SWING CHECK VALVES

Class 150	16
Class 300	17
Class 600	17
Class 900	18
Class 1500	18

CAST STAINLESS STEEL GATE VALVES

Class 150	19
Class 300	19

CAST STAINLESS STEEL GLOBE VALVES

Class 150	20
Class 300	20

CAST STAINLESS STEEL SWING CHECK VALVES

Class 150	21
Class 300	21

Standard API-600 and API-603 Packing and Gaskets	22
O-Ring Seal Block & Bleed Gate Valves	23
Cast Steel Cryogenic Gate, Globe and Check Valves	24
Pressure–Temperature Ratings	26
Terms and Conditions of Sale	28
Return Goods Policy, Warranty	29

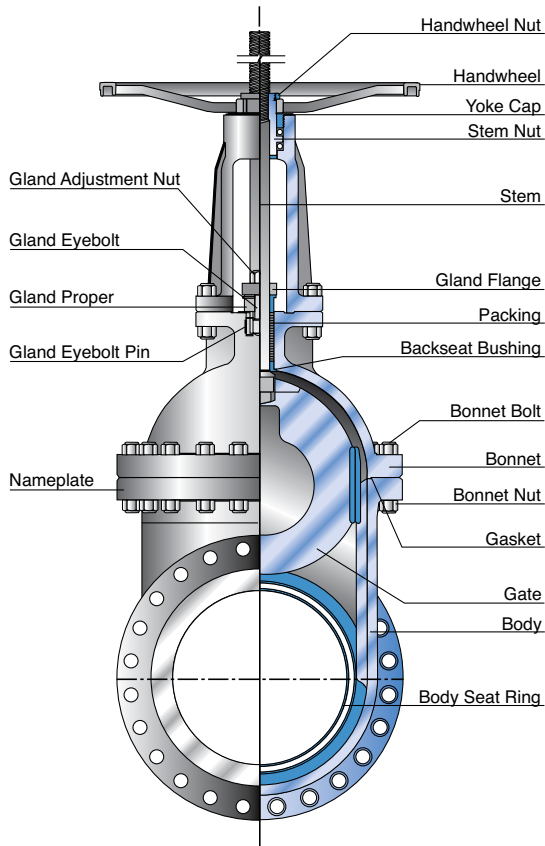

GWC Gate Valves are manufactured to the latest edition of API Standard 600 and tested to API Standard 598.

APPLICATION & FUNCTION

Gate valves are primarily used for stop valves fully opened or fully closed. They are not normally considered for throttling purposes, but more for slurries, viscous fluids, etc.

Gate valves are characterized by a traveling wedge, which is moved with the operation of the stem nut. The wedge travels perpendicular to the direction of the flow.

Gate valves usually have a minimum pressure drop when fully open, provide tight shut-off when fully closed, and remain relatively free of contamination buildup.

BODY & BONNET

The design of the body and bonnet is calculated to achieve the most regular distribution of stress in all directions, as well as the minimum turbulence and resistance to flow.

Valve bonnets are equipped with a backseat bushing. The yoke is integrally cast on Pressure Classes 150 and 300 up to 12" and up to 10" on Class 600 and higher ratings.

BODY-BONNET JOINT

Standard body-bonnet joints of gate valves are machined as follows:

PRESSURE CLASS	JOINT DESIGN
150	Flat Faced
300, 600	Male-and-Female
900* & over	Ring Type Joint

*Pressure Class 600 also available in Ring Type Joint.

GWC can supply any style of gasket required by customer.

GATE

All gates are fully guided to the seats. As standard our valves are supplied with a solid flexible gate that has a tapered H cross-section. The flexible wedge is cast or machined with a circumferential groove to allow the seating surfaces to move independently and adjust to movement of the body seats. This design is beneficial where line loads or thermal expansion of the system is likely to distort the seat face in the valve. This design of gate is ideally suited for steam or other high temperature services and is especially useful to prevent sticking where valves are closed when hot and opened when cold.

SEAT RING

Seat rings are designed to greatly reduce and/or prevent any turbulence and avoid damages due to the corrosion. The seat rings are forged or rolled in one piece, and then seal welded and overlaid, if required. After welding and all required heat treating, the seat ring faces are machined, thoroughly cleaned and inspected before leaving for assembly.

STEM

The stem connection to the gate is a T-head design which is integral (without welding) with the stem. The accuracy in the dimensions and finishes assure a long life with a perfect tightness in the packing area, resulting in lower fugitive emissions.

The stem-to-gate connection is designed to prevent the turning or the disengagement of stem from the wedge while the valve is in service.

GATE VALVE STANDARD FEATURES

Through calculations and extreme testing, the strength of the stem-to-gate connection has proven to exceed the strength of the stem at the root of its operating thread.

STEM PACKING

The stem packing is designed and arranged to ensure a maximum seal along the stem during operation or while at position, thus allowing for a greater reduction in fugitive emissions. Our packings are NON-ASBESTOS types.

GWC can supply any style of packing required by our customer.

STUFFING BOX

The depth of the stuffing box allows for a sufficient amount of packing, which makes the stem seal. Our standard packing arrangement and stuffing box design meets <100 ppm fugitive emission requirements.

If specified in the purchase order, lantern rings and/or grease injectors can be furnished.

PACKING GLAND

The packing gland design is a two-piece self-aligning type. The gland proper has a spherical head that rides within the spherical joint of the gland flange. The gland proper has a shoulder, which restricts the complete entry into the stuffing box bore. This particular design assures a straight compression of the packing as the gland eyebolts are being equally adjusted, without injuring the stem.

STEM NUT

The stem nut arrangement and design allows for the removal of the handwheel without allowing the stem and gate to drop into the closed position if the handwheel is removed while the valve is in the open position.

Ball bearings are provided in the stem nut arrangement of Class 150 valves from NPS 14", on Class 300 valves from NPS 12", on Class 600 valves from NPS 6", and on Classes 900-1500 valves from NPS 2".

HANDWHEELS

Handwheels are designed for easy operation and a comfortable grip. Our valves are also available with gearing, motor actuators or cylinder actuators for the more demanding services.

BOLTS AND NUTS

For normal service conditions, ASTM A194 Class 2H and ASTM A193 Grade B7 nuts and stud bolts are furnished. If specified for high temperature service conditions, ASTM A194 Class 4 and ASTM A193 Grade B16 nuts and stud bolts are furnished. Standard bolting furnished for our stainless steel valves consists of ASTM A194 Class 8 and ASTM A193 Grade B8 nuts and stud bolts.

GWC can supply any bolting as required by the customer.

END CONNECTIONS

Our standard production covers valves with:

- Flange ends with Raised Face (RF), Flat Face (FF) or Ring Type Joint (RTJ) that conform to B16.5.
- Butt-welding ends (BW) that conform to B16.25.
- All face-to-face/end-to-end dimensions conform to B16.10.
- Other special end connections are supplied according to customer's requirements.

ACCESSORIES

Accessories such as gear operators, actuators, bypasses, locking devices, chainwheels, extended stems and bonnets for cryogenic service and many others are available to meet the customers requirements.

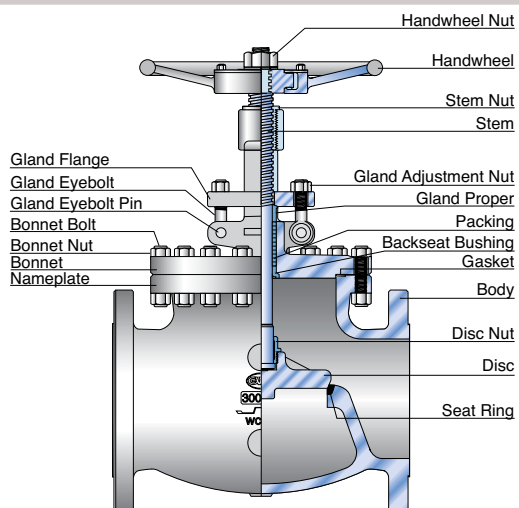

GWC Globe Valves are manufactured and modified to the latest edition of API Standard 600/ASME B16.34 and tested to API Standard 598.

APPLICATION & FUNCTION

Globe valves are primarily used as control valves where throttling or both throttling and shut-off are required. Globe valves can also be used for on-off service; however, because of the design, a pressure drop becomes inherent. This is generally confined to on-off applications where the valve is normally closed and pressure drop is not important when the valve is open. Normal applications will find the globe valve with the flow and pressure under the disc. GWC cast steel globe valves are commonly made in outside screw and yoke designs with full ports (including seat ring) and heavy-duty, conical plug type discs.

BODY & BONNET

The body is full ported and spherical in form. The design utilizes large radiuses which allow for the stresses, flow resistance and turbulence to be kept to a minimum. Valve bonnets are equipped with a backseat bushing.

BODY-COVER JOINT

Standard body-cover joints of our globe valves are machined as follows:

PRESSURE CLASS	JOINT DESIGN
150, 300, 600	Male-and-Female
900* & over	Ring Type Joint

*Pressure Class 600 also available in Ring Joint Type

GWC can supply any style of gasket required by the customer.

DISC

The valve is normally supplied with the conical plug type disc. The disc rotates freely on the stem and incorporates a differential angle from that on the seat ring. This design provides the maximum assurance of shut off, is less likely to stick in the body seat, and is considered the simplest design for field repair.

The disc is held onto the stem utilizing the disc nut and a split-ring disc retainer on 2"–4" in pressure classes 150 and 300. Larger sizes as well as pressure classes 600 and higher utilize the disc nut and a button head design which is integral with the stem. Bottom guided discs are available.

SEAT RINGS

The seat ring design, which is normally supplied, is as follows:

CLASS 150:	2"–8"/Integral 10" >/Seal Welded
CLASS 300–900:	2"–6"/Integral 8" >/Seal Welded
CLASS 1500 & >:	2"–4"/Integral 6" >/Seal Welded

Other designs are available as specified by the customer.

STEM

As GWC's standard, all stems are rotating and rising; however, a non-rotating design is available when specified by the customer. The accuracy in the dimensions and finishes assure a long life with a perfect tightness in the packing area, resulting in lower fugitive emissions. All of our stems are designed with integral backseat features which provide an ultimate seal during packing changes.

STUFFING BOX

The depth of the stuffing box allows for a sufficient amount of packing, which makes the stem seal. GWC's standard packing arrangement and stuffing box design meets <100 ppm fugitive emission requirements.

If specified in the purchase order, lantern rings and/or grease injectors can be furnished.

STEM PACKING

The stem packing is designed and arranged to ensure a maximum seal along the stem during operation or while at position, thus allowing for a greater reduction in fugitive emissions. Our packings are of non-asbestos types.

GWC can supply any style of packing required by the customer.

PACKING GLAND

The packing gland design is a two-piece self-aligning type. The gland proper has a spherical head that rides within the spherical joint of the gland flange. The gland proper has a shoulder, which restricts the complete entry into the stuffing box bore. This particular design assures a straight compression of the packing as the gland eyebolts are being equally adjusted, without injuring the stem.

STEM NUT

The stem nuts on GWC's standard rising stem globe valves are threaded into the top of the yoke where they are secured with a tack weld.

OPERATION

Handwheels are designed with a comfortable grip for easy operation. As our standard, hammer-blow type handwheels are provided as listed in the next column:

PRESSURE CLASS	JOINT DESIGN
150	8" and larger
300 – 600	6" and larger
900 and over	4" and larger

Our valves are also available with gearing, motor actuators or cylinder actuators for the more demanding services.

BOLTS AND NUTS

For normal service conditions, ASTM A194 Class 2H and ASTM A193 Grade B7 nuts and stud bolts are furnished. If specified for high temperature service conditions, ASTM A194 Class 4 and ASTM A193 Grade B16 nuts and stud bolts are furnished. Standard bolting furnished for our stainless steel valves consists of ASTM A194 Class 8 and ASTM A193 Grade B8 nuts and stud bolts.

GWC can supply any bolting as requested by the customer.

END CONNECTIONS

Our standard production covers valves with:

- Flange ends with Raised Face (RF), Flat Face (FF) or Ring Type Joint (RTJ) that conform to B16.5.
- Butt-welding ends (BW) that conform to B16.25.
- All face-to-face/end-to-end dimensions conform to B16.10.
- Other special end connections are supplied according to customer's requirements.

ACCESSORIES

Accessories such as gear operators, actuators, bypasses, locking devices, chainwheels, extended stems and bonnets for cryogenic service and many others are available to meet the customers requirements.

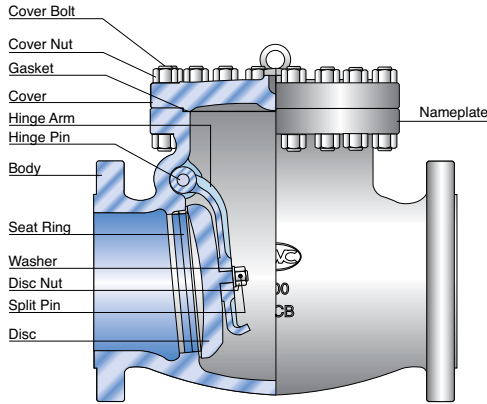

GWC Swing Check Valves are manufactured and modified to the latest edition of API Standard 600/ASME B16.34 and tested to API Standard 598.

APPLICATION & FUNCTION

Swing check valves are designed to close quickly and automatically with positive shut off in either horizontal or vertical (flow up) pipe runs.

Inherently, swing check valves have a low pressure drop and are best suitable for velocity applications.

Our closure design allows our swing check valve to close completely even and remain closed with no flow when installed in a horizontal pipe run.

BODY

The body is full ported and spherical in form. The design utilizes large radiuses which allow for the stresses, flow resistance and turbulence to be kept to a minimum. Bosses are provided for optional drains.

BODY-COVER JOINT

Standard body-cover joints of our swing check valves are machined as follows:

PRESSURE CLASS

150, 300, 600
900* & over

JOINT DESIGN

Male-and-Female
Ring Type Joint

*Pressure Class 600 also available in Ring Type Joint.

GWC can supply any style of gasket required by customer.

HINGE ASSEMBLY

The hinge arm pivots on the hinge pin which is located near the disc's center of gravity. Body penetration for the hinge pin is sealed with a soft steel gasket and flanged plug. The hinge arm is designed to withstand the shock load of quick closing to insure a longer life and continued shut-off. The hinge arm also has an integral disc stop that provides a positive stop in the open position.

DISC

Each disc's seating surface is precision ground and mated to the seat ring for insurance of a positive shut off. The disc is secured to the hinge arm with the disc nut and pinned to prevent disengagement during service. We can provide either integral or overlaid seat facings at customer's request.

SEAT RING

Seat rings are designed to greatly reduce and/or prevent any turbulence and avoid damages due to corrosion. The seat rings are forged or rolled in one piece and then seal welded and overlaid, if required. After welding and all required heat treating, the seat ring faces are machined, thoroughly cleaned and inspected before leaving for assembly.

BOLTS AND NUTS

For normal service conditions, ASTM A194 Class 2H and ASTM A193 Grade B7 nuts and stud bolts are furnished. If specified for high temperature service conditions, ASTM A194 Class 4 and ASTM A193 Grade B16 nuts and stud bolts are furnished. Standard bolting furnished for our stainless steel valves consists of ASTM A194 Class 8 and ASTM A193 Grade B8 nuts and stud bolts.

GWC can supply any bolting as requested by the customer.

END CONNECTIONS

Our standard production covers valves with:

- Flange ends with Raised Face (RF), Flat Face (FF) or Ring Type Joint (RTJ) that conform to B16.5.
- Butt-welding ends (BW) that conform to B16.25.
- All face-to-face/end-to-end dimensions conform to B16.10.
- Other special end connections are supplied according to customer's requirements.

ACCESSORIES/OPTIONAL DESIGNS

Counterweight features are available as an accessory. Tilting disc or hydrofoil designs are also available to meet the customers requirements. Drains and bypasses are available as specified by the customer.

Example: 8" Figure #1900-I-5-GO

1 90 0 - I - 5 - GO
 1. 2. 3. 4. 5. 6.

8" Gate Valve, ANSI Class 900, RF Flanged, WC6 Body, 13CR Full Stellite Trim, Bevel Gear Operator

1. MODEL

1 - API 600 GATE VALVE	24 - ANGLE GLOBE VALVE
2 - API 600 GLOBE VALVE	26 - STOP CHECK VALVE
3 - API 600 SWING CHECK VALVE	34 - TILTING DISC CHECK VALVE
4 - API 603 GATE VALVE	36 - PISTON CHECK VALVE
5 - API 603 GLOBE VALVE	81 - API-6D GATE VALVE
6 - API 603 SWING CHECK VALVE	83 - API-6D SWING CHECK VALVE

2. RATING

15 - CLASS 150	90 - CLASS 900
30 - CLASS 300	150 - CLASS 1500
60 - CLASS 600	

3. END CONNECTION

0 - RF FLANGED	9 - RING JOINT
6 - FF FLANGED	X - OTHER
7 - BUTTWELD	

4. MATERIAL (BODY + BONNET/CAP)

A - WCB	K - C5	R - CN7M
B - WCC	L - C12	S - A890 4A
C - LCC	M - CF8	T - A890 5A
D - LCB	N - CF8M	U - A890 6A
H - WC1	O - CF3	X - OTHER
I - WC6	P - CF3M	
J - WC9	Q - CF8C	

5. MATERIAL (TRIM)

1 - 13CR	12 - 316SS 1/2 STELLITE	17H - 347SS 1/2 STELLITE
8 - 13CR 1/2 STELLITE	16 - 316SS FULL STELLITE	17S - 347SS FULL STELLITE
5 - 13CR FULL STELLITE	9 - MONEL	21 - F51
2 - 304SS	11 - MONEL 1/2 STELLITE	22 - F53
2S - 304SS 1/2 STELLITE	13 - ALLOY 20	23 - F55
15 - 304SS FULL STELLITE	14 - ALLOY 20 1/2 STELLITE	O - OTHER
10 - 316SS	17 - 347SS	

6. OPERATOR

- HANDWHEEL OPERATOR	B - BARE STEM
GO - BEVEL GEAR OPERATOR	

7. SPECIAL REQUIREMENT

N - NACE MR-01-75	EB - EXTENDED BONNET
S - SUPPLY COMPLETE INFORMATION	Y - "Y" PATTERN

CAST STEEL GATE VALVES

STANDARD PARTS & MATERIALS

NO.	PART NAME	CARBON STEEL		ALLOY STEEL				STAINLESS STEEL
		TYPE WCB	TYPE LCB	TYPE WC6	TYPE WC9	TYPE C5	TYPE C12	TYPE CF8M
1	BODY ¹	A216WCB	A352-LCB	A217-WC6	A217-WC9	A217-C5	A217-C12	A351-CF8M
2	BONNET ¹	A216WCB	A352-LCB	A217-WC6	A217-WC9	A217-C5	A217-C12	A351-CF8M
3	GATE ¹	A217 CA15 or WCB+410	A351 CF8M or LCB+316	A217 CA15 or WCB+410	A217 CA15 or WC9+410	A217 CA15 or C5+410	A217 CA15 or C12+410	A351-CF8M
4	SEAT RING ¹	A576-1020+STL ²	A182-316	A182F11+STL ²	F22+STL ²	F5a+STL ²	F9+STL ²	A479-316
5	YOKE	A216WCB	LCB/WCB	WC6/WCB	WC9/WCB	C5/WCB	C12/WCB	A351-CF8
6	HANDWHEEL	A197 or WCB	A197 or WCB	A197 or WCB	A197 or WCB	A197 or WCB	A197 or WCB	A197 or WCB
7	STEM	A479-410	A479-316	A479-410	A479-410	A479-410	A479-410	A479-316
8	BACKSEAT BUSHING ¹	A479-410	A479-316	A479-410	A479-410	A479-410	A479-410	A479-316
9	GLAND FLANGE	A105	A105	A105	A105	A105	A105	A351-CF8
10	STEM NUT	A439-D2	A439-D2	A439-D2	A439-D2	A439-D2	A439-D2	A439-D2
11	GLAND PROPER	C/S 1020+Cr Plate	C/S 1020+Cr Plate	C/S 1020+Cr Plate	C/S 1020+Cr Plate	C/S 1020+Cr Plate	C/S 1020+Cr Plate	A479-316
12	YOKE CAP	C/S1020	C/S1020	C/S1020	C/S1020	C/S1020	C/S1020	A576-1020
13	BONNET BOLT	A193-B7	A320-L7	A193-B16	A193-B16	A193-B16	A193-B16	A193-B8
14	BONNET NUT	A194-2H	A194-4	A194-4	A194-4	A194-4	A194-4	A194-8
15	GLAND EYEBOLT	A307B	A307B	A193-B7	A193-B7	A193-B7	A193-B7	A193-B8
16	GLAND ADJUSTMENT NUT	A307B	A307B	A194-2H	A194-2H	A194-2H	A194-2H	A194-8
17	HANDWHEEL NUT	A47 Gr 32510	A47 Gr 32510	A47 Gr 32510	A47 Gr 32510	A47 Gr 32510	A47 Gr 32510	A47 Gr 32510
18	GLAND EYEBOLT PIN	C/S 1020	C/S 1020	C/S 1020	C/S 1020	C/S 1020	C/S 1020	A479-304
19	PACKING ¹	See Standard Packing & Gasket Material Chart on Page 24.						
20	GASKET ¹	See Standard Packing & Gasket Material Chart on Page 24.						
21	YOKE BOLT	A193-B7	A193-B7	A193-B7	A193-B7	A193-B7	A193-B7	A193-B8
22	YOKE NUT	A194-2H	A194-2H	A194-2H	A194-2H	A194-2H	A194-2H	A194-8
23	NAMEPLATE	Stainless Steel	Stainless Steel	Stainless Steel	Stainless Steel	Stainless Steel	Stainless Steel	Stainless Steel

¹Other materials available on request.

²STL = Stellite #6.

MODEL 1150 / 1157 / 1159

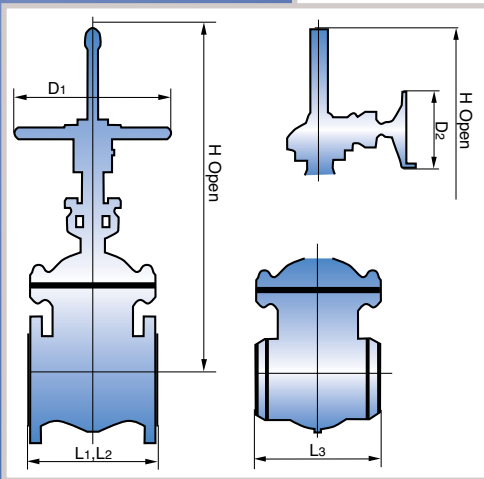

Cast steel gate valve, outside screw and yoke, bolted bonnet, rising stem, non-rising handwheel, flexible wedge, available in welded seat rings, designed according to API-600.

DIMENSIONS

Face to Face	ASME B16.10
End Flange	ASME B16.5*
Buttweld	ASME B16.25
Rating	ASME Class 150

* 26" and larger are available with ASME B16.47 end flanges, either Series A or Series B (formerly MSS SP-44 and API 605).

CLASS 150

Dimensions in inches

Valve Size		1-1/2" 40mm	2" 50mm	2-1/2" 65mm	3" 80mm	4" 100mm	6" 150mm	8" 200mm	10" 250mm	12" 300mm	14" 350mm	16" 400mm	18" 450mm	20" 500mm	24" 600mm	30" 750mm	36" 900mm
Face to Face	L1: RF	6.50	7.00	7.50	8.00	9.00	10.50	11.50	13.00	14.00	15.00	16.00	17.00	18.00	20.00	24.00	28.00
	L2: RTJ	7.00	7.50	8.00	8.50	9.50	11.00	12.00	13.50	14.50	15.50	16.50	17.50	18.50	20.50	-	-
	L3: BW	6.50	8.50	9.50	11.13	12.00	15.88	16.50	18.00	19.75	22.50	24.00	26.00	28.00	32.00	36.00	40.00
Valve Open Height (H)		12.76	14.45	15.63	18.03	22.05	30.04	37.80	45.91	53.90	59.65	71.80	74.80	83.50	98.50	126.00	140.20
Handwheel Diameter (D1)		7.09	7.87	7.87	8.82	9.84	12.40	13.98	15.75	17.72	19.69	22.05	24.80	27.95	31.50	35.43	43.00
Handwheel Diameter (D2)		-	-	-	-	12.40	12.40	12.40	13.98	15.75	15.75	15.75	17.72	17.72	19.69	27.95	31.50
Weight (lbs.)	RF	36	41	58	73	106	192	284	397	618	904	1,279	1,488	1,856	3,042	4,630	6,400
	BW	31	36	47	61	86	166	242	327	513	774	1,126	1,296	1,632	2,703	3,944	6,305

CAST STEEL GATE VALVES

MODEL 1300 / 1307 / 1309

Cast steel gate valve, outside screw and yoke, bolted bonnet, rising stem, non-rising handwheel, flexible wedge, available in welded seat rings, designed according to API-600.

DIMENSIONS

Face to Face	ASME B16.10
End Flange	ASME B16.5*
Buttweld	ASME B16.25
Rating	ASME Class 300

* 26" and larger are available with ASME B16.47 end flanges, either Series A or Series B (formerly MSS SP-44 and API 605).

CLASS 300

Dimensions in inches

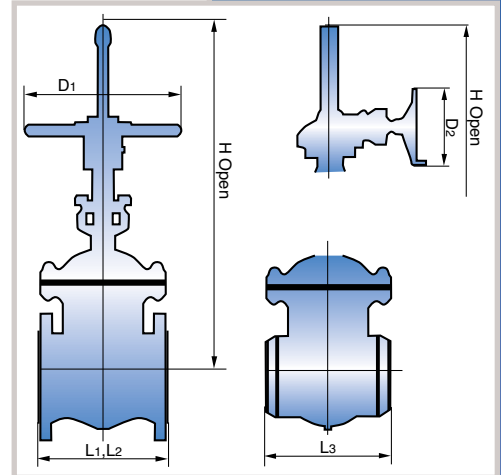

Valve Size		1-1/2" 40mm	2" 50mm	2-1/2" 65mm	3" 80mm	4" 100mm	6" 150mm	8" 200mm	10" 250mm	12" 300mm	14" 350mm	16" 400mm	18" 450mm	20" 500mm	24" 600mm	30" 750mm	36" 900mm
Face to Face	L1: RF	7.50	8.50	9.50	11.13	12.00	15.83	16.50	18.00	19.75	30.00	33.00	36.00	39.00	45.00	55.00	68.00
	L2: RTJ	8.00	8.13	10.13	11.83	12.63	16.50	17.13	18.63	20.38	30.63	33.63	36.63	39.75	45.83	56.00	59.00
	L3: BW	7.50	8.50	9.50	11.13	12.00	15.83	16.50	18.00	19.75	30.00	33.00	36.00	39.00	45.00	55.00	68.00
Valve Open Height (H)		15.00	15.94	17.32	19.69	23.31	32.13	41.02	48.31	56.77	62.52	74.41	80.31	86.50	121.18	127.60	159.06
Handwheel Diameter (D1)		7.87	7.87	7.87	8.82	9.84	13.98	15.75	17.72	19.69	22.05	24.80	27.95	31.50	35.43	51.02	63.00
Handwheel Diameter (D2)		-	-	-	-	12.40	12.40	12.40	13.98	15.75	15.75	19.69	19.69	19.69	24.80	31.50	51.02
Weight (lbs).	RF	40	58	75	110	165	317	550	704	1,056	1,496	2,139	2,772	3,545	5,346	8,316	16,698
	BW	29	49	60	84	119	251	462	561	808	1,232	1,793	2,354	3,058	4,367	7,040	14,960

MODEL 1600 / 1607 / 1609

Cast steel gate valve, outside screw and yoke, bolted bonnet, rising stem, non-rising handwheel, flexible wedge, available in welded seat rings, designed according to API-600.

DIMENSIONS

Face to Face	ASME B16.10
End Flange	ASME B16.5*
Buttweld	ASME B16.25
Rating	ASME Class 600

* 26" and larger are available with ASME B16.47 end flanges, either Series A or Series B (formerly MSS SP-44 and API 605).

CLASS 600

Dimensions in inches

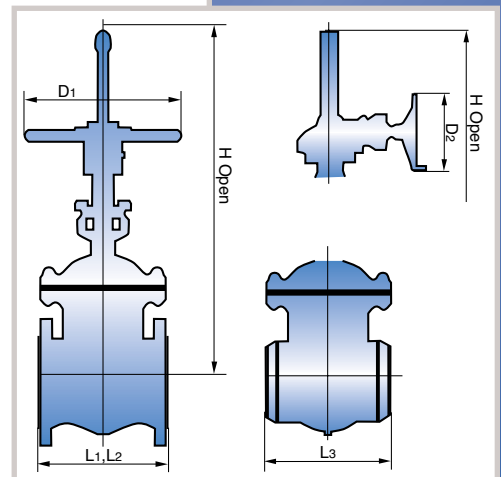

Valve Size		2" 50mm	2-1/2" 65mm	3" 80mm	4" 100mm	6" 150mm	8" 200mm	10" 250mm	12" 300mm	14" 350mm	16" 400mm	18" 450mm	20" 500mm	24" 600mm	30" 750mm
Face to Face	L1: RF	11.50	13.00	14.00	17.00	22.00	26.00	31.00	33.00	35.00	39.00	43.00	47.00	55.00	65.00
	L2: RTJ	11.63	13.13	14.13	17.13	22.13	26.13	31.13	33.13	35.13	39.13	43.13	47.25	55.38	65.50
	L3: BW	11.50	13.00	14.00	17.00	22.00	26.00	31.00	33.00	35.00	39.00	43.00	47.00	55.00	65.00
Valve Open Height (H)		16.65	17.99	20.12	25.00	37.72	42.44	48.86	56.69	50.09	71.06	78.11	79.92	107.00	155.98
Handwheel Diameter (D1)		7.87	8.82	9.84	13.98	17.72	19.69	24.80	27.95	31.50	35.43	35.43	42.99	42.99	63.00
Handwheel Diameter (D2)		-	-	-	12.40	15.75	17.72	19.69	22.05	24.80	27.96	27.96	31.50	31.50	35.43
Weight (lbs).	RF	80	113	143	277	532	935	1,385	1,984	2,658	3,108	4,891	6,197	8,656	14,840
	BW	69	97	122	220	423	744	1,102	1,578	2,283	2,473	42,40	5,371	7,473	12,810

CAST STEEL GATE VALVES

MODEL 1900 / 1907 / 1909

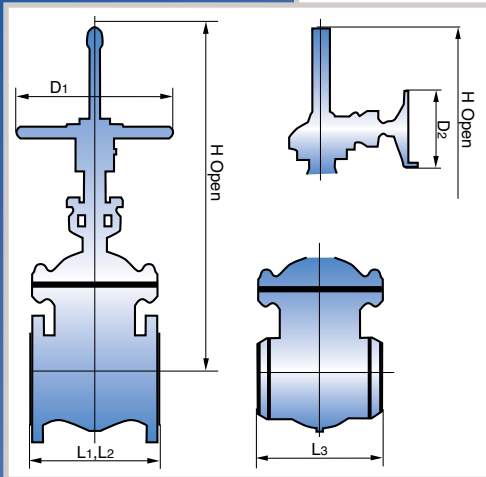

Cast steel gate valve, outside screw and yoke, bolted bonnet, rising stem, non-rising handwheel, flexible wedge, available in welded seat rings, designed according to API-600.

DIMENSIONS

Face to Face	ASME B16.10
End Flange	ASME B16.5
Buttweld	ASME B16.25
Rating	ASME Class 900

CLASS 900

Dimensions in inches

Valve Size		2" 50mm	3" 80mm	4" 100mm	6" 150mm	8" 200mm	10" 250mm	12" 300mm	14" 350mm	16" 400mm	18" 450mm	20" 500mm	24" 600mm
Face to Face	L1: RF	14.50	15.00	18.00	24.00	29.00	33.00	38.00	40.50	44.50	48.00	52.00	61.00
	L2: RTJ	14.63	15.13	18.13	24.13	29.13	33.13	38.13	40.87	44.87	48.50	52.50	61.75
	L3: BW	14.50	15.00	18.00	24.00	29.00	33.00	38.00	40.50	44.50	48.00	52.00	61.00
Valve Open Height (H)		18.66	23.03	27.64	37.72	50.98	57.13	65.16	72.52	84.61	87.80	97.10	111.81
Handwheel Diameter (D1)		9.84	13.98	13.98	19.69	24.80	24.80	31.50	35.43	35.43	42.99	42.99	42.99
Handwheel Diameter (D2)		-	-	-	17.72	22.05	24.80	24.80	27.95	27.95	31.50	35.43	35.43
Weight (lbs).	RF	178	219	307	750	1,279	1,963	3,160	4,395	5,940	7,662	9,620	14,454
	BW	165	191	251	641	1,113	1,552	2,670	3,740	5,078	6,534	8,010	12,117

MODEL 11500 / 11507 / 11509

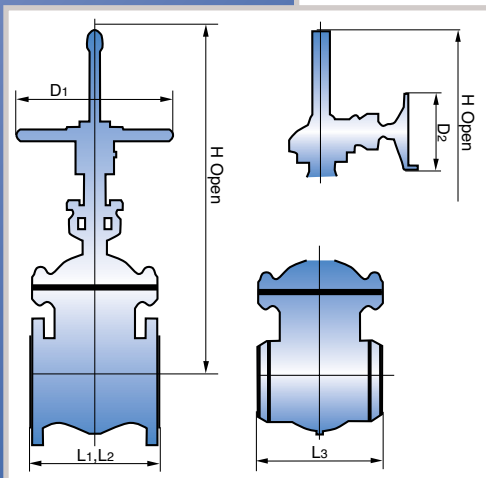

Cast steel gate valve, outside screw and yoke, bolted bonnet, rising stem, non-rising handwheel, flexible wedge, available in welded seat rings, designed according to API-600.

DIMENSIONS

Face to Face	ASME B16.10
End Flange	ASME B16.5
Buttweld	ASME B16.25
Rating	ASME Class 1500

Dimensions in inches

CLASS 1500

Valve Size		2" 50mm	3" 80mm	4" 100mm	6" 150mm	8" 200mm	10" 250mm	12" 300mm	14" 350mm	16" 400mm	18" 450mm	20" 500mm	24" 600mm
Face to Face	L1: RF	14.50	15.00	18.00	24.00	29.00	33.00	44.50	49.50	54.50	60.50	65.50	76.50
	L2: RTJ	14.63	18.63	21.63	28.00	33.13	39.37	45.13	50.25	55.37	61.37	66.37	77.63
	L3: BW	14.50	15.00	18.00	24.00	32.75	33.00	44.50	49.50	54.50	60.50	65.50	76.50
Valve Open Height (H)		18.66	23.74	28.70	37.17	53.50	57.13	67.13	74.49	90.12	93.31	104.96	119.69
Handwheel Diameter (D1)		9.84	13.98	13.98	19.69	24.80	24.80	35.43	35.43	35.43	35.43	35.43	-
Handwheel Diameter (D2)		-	-	17.72	17.72	27.95	27.95	27.95	31.50	35.43	35.43	42.99	42.99
Weight (lbs).	RF	178	312	529	1,114	2,351	3,840	6,464	8,150	13,300	17,820	22,037	32,210
	BW	165	246	423	896	2,058	3,050	5,270	6,340	11,800	15,325	18,920	27,264

STANDARD PARTS AND MATERIALS

NO.	PART NAME	CARBON STEEL		ALLOY STEEL				STAINLESS STEEL
		TYPE WCB	TYPE LCB	TYPE WC6	TYPE WC9	TYPE C5	TYPE C12	TYPE CF8M
1	BODY ¹	A216-WCB	A352-LCB	A217-WC6	A217-WC9	A217-C5	A217-C12	A351-CF8M
2	BONNET ¹	A216-WCB	A352-LCB	A216-WC6	A217-WC9	A217-C5	A217-C12	A351-CF8M
3	DISC ¹	A217 CA15 or WCB+410	A351 CF8M or LCB+316	A217 CA15 or WCB+410	A217 CA15 or WC9+410	A217 CA15 or C5+410	A217 CA15 or C12+410	A351-CF8M
4	STEM	A479-410	A479-316	A479-410	A479-410	A479-410	A479-410	A479-316
5	HANDWHEEL	A216-WCB or A197	A216-WCB or A197	A216-WCB or A197	A216-WCB or A197	A216-WCB or A197	A216-WCB or A197	A216-WCB or A197
6	SEAT RING ¹	C/S 1020+410	A182-F304	A182F11+STL ²	A182F22+STL ²	A182F5a+STL ²	A182F9+STL ²	A479-316
7	BACKSEAT BUSHING ¹	A479-410	A479-304	A479-410	A479-410	A479-410	A479-410	A479-316
8	GLAND PROPER	C/S 1020 + Cr Plate	A479-410	A479-410	A479-410	A479-410	A479-410	A479-316
9	GLAND FLANGE	A105 or A283-D	A105 or A283-D	A105 or A283-D	A105 or A283-D	A105 or A283-D	A105 or A283-D	A351-CF8
10	STEM NUT	A439-D2	A439-D2	A439-D2	A439-D2	A439-D2	A439-D2	A439-D2
11	BONNET BOLT	A193-B7	A320-L7	A193-B16	A193-B16	A193-B16	A193-B16	A193-B8
12	BONNET NUT	A194-2H	A194-4	A194-4	A194-4	A194-4	A194-4	A194-8
13	GLAND EYEBOLT	A307B	A307B	193-B7	193-B7	193-B7	193-B7	A193-B8
14	GLAND ADJUSTMENT NUT	A307B	A307B	A194-2H	A194-2H	A194-2H	A194-2H	A194-8
15	GLAND EYEBOLT PIN	C/S 1020	C/S 1020	C/S 1020	C/S 1020	C/S 1020	C/S 1020	A479-304
16	DISC NUT	A479-410	A479-304	A479-410	A479-410	A479-410	A479-410	A479-316
17	HANDWHEEL NUT	A307B	A307B	A307B	A307B	A307B	A307B	A194-8
18	PACKING ¹	See Standard Packing & Gasket Material Chart on Page 24.						
19	GASKET ¹	See Standard Packing & Gasket Material Chart on Page 24.						
20	NAMEPLATE	Stainless Steel	Stainless Steel	Stainless Steel	Stainless Steel	Stainless Steel	Stainless Steel	Stainless Steel

¹Other materials available on request.

²STL = Stellite #6.

MODEL 2150 / 2157 / 2159

Cast steel globe valve, outside screw and yoke, bolted bonnet, rising stem, rising handwheel, swivel plug disc. Available in integral and weld in type seat rings designed according to API-600/ASME B16.34.

DIMENSIONS

Face to Face	ASME B16.10
End Flange	ASME B16.5
Buttweld	ASME B16.25
Rating	ASME Class 150

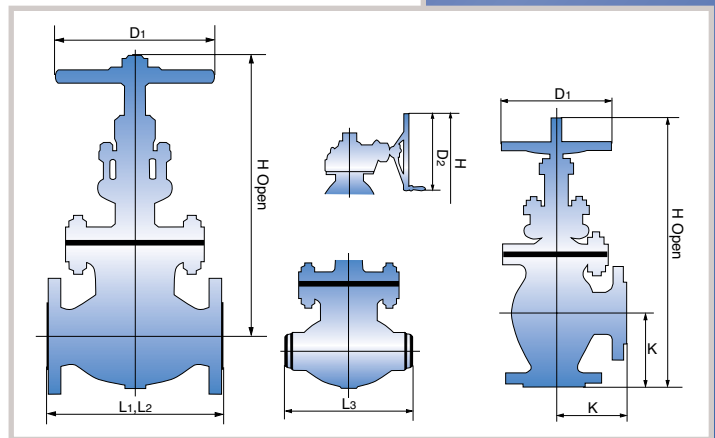

Dimensions in inches

Valve Size		1-1/2" 40mm	2" 50mm	2-1/2" 65mm	3" 80mm	4" 100mm	6" 150mm	8" 200mm	10" 250mm	12" 300mm	14" 350mm	16" 400mm	18" 450mm	20" 500mm
Face to Face	L1: RF	6.50	8.00	8.50	9.50	11.50	16.00	19.50	24.50	27.50	31.00	36.00	38.50	38.50
	L2: RTJ	7.00	8.50	9.00	10.00	12.00	16.50	20.00	25.00	28.00	31.50	36.50	39.00	39.00
	L3: BW	6.50	8.00	8.50	9.50	11.50	16.00	19.50	24.50	27.50	31.00	36.00	38.50	38.50
	K: RF/BW	3.25	4.00	4.25	4.75	5.75	8.00	9.75	12.25	13.75	15.50	18.00	-	-
Valve Open Height (H)		11.42	12.44	12.99	14.37	16.30	19.87	24.53	31.61	33.03	52.99	60.98	70.00	78.98
Handwheel Diameter (D1)		7.09	2.87	2.87	8.82	11.02	13.98	15.75	17.72	19.69	22.05	24.80	31.50	31.50
Handwheel Diameter (D2)		-	-	-	-	-	13.98	17.72	17.72	19.69	22.05	24.80	27.95	31.50
Weight (lbs.)	RF	38	46	62	75	114	209	371	534	891	1,365	1,808	2,156	2,822
	BW	33	36	53	60	90	163	316	426	786	1,234	1,655	1,964	2,597

CLASS 150

CAST STEEL GLOBE & ANGLE VALVES

MODEL 2300 / 2307 / 2309

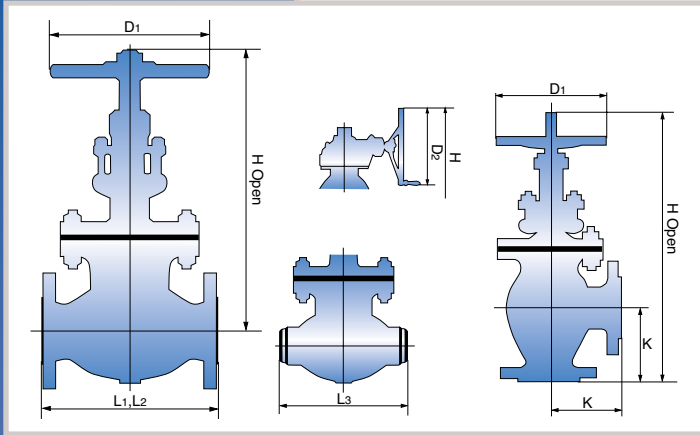

Cast steel globe valve, outside screw and yoke, bolted bonnet, rising stem, rising handwheel, swivel plug disc. Available in integral and weld in type seat rings designed according to API-600/ASME B16.34

DIMENSIONS

Face to Face	ASME B16.10
End Flange	ASME B16.5
Buttweld	ASME B16.25
Rating	ASME Class 300

Dimensions in inches

CLASS 300

Valve Size	2" 50mm	2-1/2" 65mm	3" 80mm	4" 100mm	6" 150mm	8" 200mm	10" 250mm	12" 300mm	14" 350mm	16" 400mm
Face to Face	L1: RF	10.50	11.50	12.50	14.00	17.50	22.00	24.50	28.00	34.00
	L2: RTJ	11.13	12.13	13.13	14.63	18.13	22.63	25.13	28.63	34.63
	L3: BW	10.50	11.50	12.50	14.00	17.50	22.00	24.50	28.00	34.00
	K: RF/BW	5.25	5.75	6.25	7.00	8.75	11.00	12.25	14.00	-
Valve Open Height (H)	13.78	15.39	16.54	19.37	24.41	31.22	45.08	49.61	55.28	62.99
Handwheel Diameter (D1)	7.87	8.82	11.02	13.98	17.72	22.05	22.05	24.80	27.95	27.95
Handwheel Diameter (D2)	-	-	-	-	17.72	19.69	22.05	24.80	24.80	27.96
Weight (lbs).	RF	58	88	116	176	370	1,005	1,340	2,008	2,650
	BW	53	80	94	142	299	440	860	1,143	1,720

MODEL 2600 / 2607 / 2609

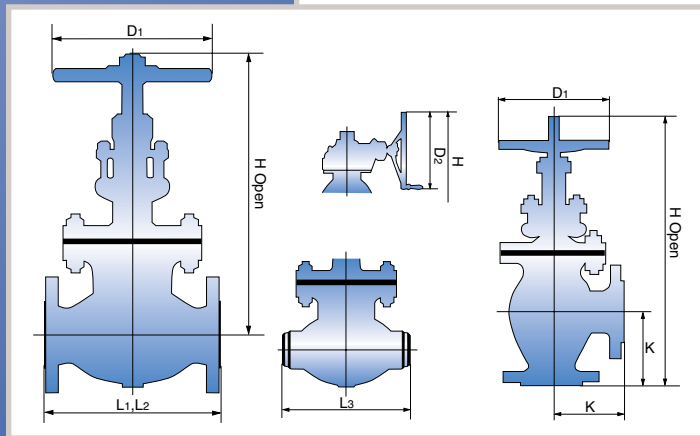

Cast steel globe valve, outside screw and yoke, bolted bonnet, rising stem, rising handwheel, swivel plug disc. Available in integral and weld in type seat rings designed according to API-600/ASME B16.34

DIMENSIONS

Face to Face	ASME B16.10
End Flange	ASME B16.5
Buttweld	ASME B16.25
Rating	ASME Class 600

Dimensions in inches

CLASS 600

Valve Size	2" 50mm	2-1/2" 65mm	3" 80mm	4" 100mm	6" 150mm	8" 200mm	10" 250mm	12" 300mm	
Face to Face	L1: RF	11.50	13.00	14.00	17.00	22.00	26.00	33.00	
	L2: RTJ	11.63	13.13	14.13	17.13	22.13	26.13	33.13	
	L3: BW	11.50	13.00	14.00	17.00	22.00	26.00	33.00	
	K: RF/BW	5.25	5.75	6.25	8.00	9.75	11.75	15.00	
Valve Open Height (H)	15.43	17.00	18.82	20.87	26.57	28.39	38.27	42.28	
Handwheel Diameter (D1)	8.82	11.02	12.40	13.98	19.69	22.05	24.80	27.95	
Handwheel Diameter (D2)	-	-	-	13.98	19.69	22.05	22.05	24.80	
Weight (lbs).	RF	82	89	137	253	525	800	1,505	1,984
	BW	68	70	109	198	415	637	1,235	1,671

CAST STEEL GLOBE & ANGLE VALVES

MODEL 2900 / 2907 / 2909

Cast steel globe valve, outside screw and yoke, bolted bonnet, rising stem, rising handwheel, swivel plug disc. Available in integral and weld in type seat rings designed according to API-600/ASME B16.34

DIMENSIONS

Face to Face	ASME B16.10
End Flange	ASME B16.5
Buttweld	ASME B16.25
Rating	ASME Class 900

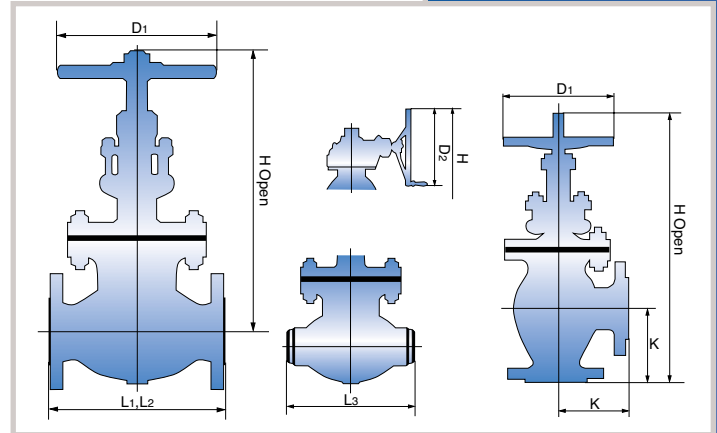

Dimensions in inches

Valve Size		2" 50mm	3" 80mm	4" 100mm	6" 150mm	8" 200mm	10" 250mm	12" 300mm
Face to Face	L1: RF	14.50	15.00	18.00	24.00	29.00	33.00	38.00
	L2: RTJ	14.63	15.13	18.13	24.13	29.13	33.13	38.13
	L3: BW	14.50	15.00	18.00	24.00	29.00	33.00	38.00
	K: RF/BW	7.25	7.50	9.00	12.00	-	-	-
Valve Open Height (H)		19.57	20.20	23.74	28.70	38.10	55.40	61.00
Handwheel Diameter (D1)		12.40	13.98	15.75	22.05	24.80	27.95	31.50
Handwheel Diameter (D2)		-	-	15.75	19.69	22.05	24.80	27.95
Weight (lbs.)	RF	215	225	390	920	2,673	4,050	5,247
	BW	160	180	330	650	2,370	3,700	4,752

CLASS 900

MODEL 21500 / 21507 / 21509

Cast steel globe valve, outside screw and yoke, bolted bonnet, rising stem, rising handwheel, swivel plug disc. Available in integral and weld in type seat rings designed according to API-600/ASME B16.34

DIMENSIONS

Face to Face	ASME B16.10
End Flange	ASME B16.5
Buttweld	ASME B16.25
Rating	ASME Class 1500

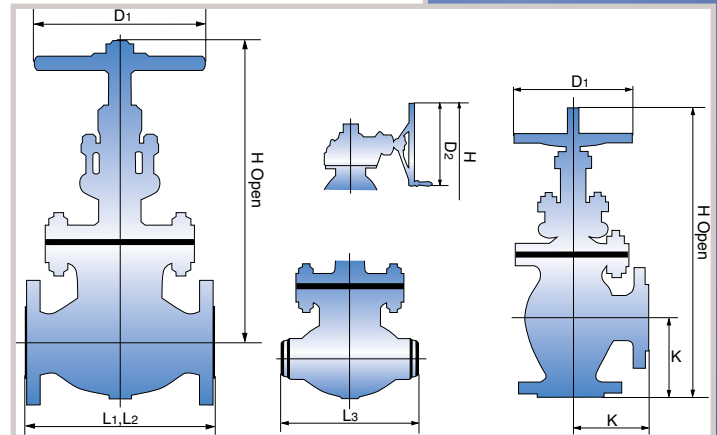

Dimensions in inches

Valve Size		2" 50mm	3" 80mm	4" 100mm	6" 150mm	8" 200mm	10" 250mm	12" 300mm
Face to Face	L1: RF	14.50	18.50	21.50	27.75	32.75	39.00	44.50
	L2: RTJ	14.62	18.62	21.62	28.00	33.12	39.38	45.13
	L3: BW	14.50	18.50	21.50	27.75	32.75	39.00	44.50
	K: RF/BW	7.25	8.25	9.25	10.75	13.88	-	-
Valve Open Height (H)		19.57	23.00	28.10	36.00	46.90	58.00	65.00
Handwheel Diameter (D1)		12.40	15.75	15.75	20.00	24.80	28.00	31.50
Handwheel Diameter (D2)		-	13.98	15.75	24.80	27.96	31.50	31.50
Weight (lbs.)	RF	215	462	772	1,810	4,170	6,330	8,712
	BW	160	265	425	1,500	3,540	5,544	7,524

CLASS 1500

CAST STEEL SWING CHECK VALVES

STANDARD PARTS & MATERIALS

NO.	PART NAME	CARBON STEEL		ALLOY STEEL				STAINLESS STEEL
		TYPE WCB	TYPE LCB	TYPE WC6	TYPE WC9	TYPE C5	TYPE C12	TYPE CF8M
1	BODY ¹	A216-WCB	A352-LCB	A217-WC6	A217-WC9	A217-C5	A217-C12	A351-CF8M
2	COVER ¹	A216-WCB	A352-LCB	A217-WC6	A217-WC9	A217-C5	A217-C12	A351-CF8M
3	DISC ¹	A217 CA15 or WCB+410	A351 CF8M or LCB+316	A217 CA15 or WC9+410	A217 CA15 or WC9+410	A217 CA15 or C5+410	A217 CA15 or C12+410	A351-CF8M
4	SEAT RING ¹	A105	A182-F316	A182F11+STL ²	F22+STL ²	F5a+STL ²	F9+STL ²	A479-316
5	HINGE ARM ¹	A216-WCB	A352-LCB	A217-WC6	A217-WC9	A217-C5	A217-C12	A351-CF8M
6	DISC NUT	A194 Gr8	A194 Gr8	A194 Gr8	A194 Gr8	A194 Gr8	A194 Gr8	A194-8
7	WASHER	A240-304	A240-316	A240-304	A240-304	A240-304	A240-304	A240-316
8	SPLIT PIN	A580-304	A580-316	A580-304	A580-304	A580-304	A580-304	A580-316
9	COVER BOLT	A193-B7	A320-L7	A193-B16	A193-B16	A193-B16	A193-B16	A193-B8
10	COVER NUT	A194-SH	A194-4	A194-4	A194-4	A194-4	A194-4	A194-8
11	HINGE PIN	A479-410	A479-410	A479-410	A479-410	A479-410	A479-410	A479-316
12	FLANGED PLUG	A479-410	A479-304	A479-304	A479-304	A479-304	A479-304	A479-316
13	GASKET ¹	See Standard Packing & Gasket Material Chart on Page 24.						
14	PLUG GASKET	Soft Steel	Soft Steel	Soft Steel	Soft Steel	Soft Steel	Soft Steel	Stainless Steel
15	NAMEPLATE	Stainless Steel	Stainless Steel	Stainless Steel	Stainless Steel	Stainless Steel	Stainless Steel	Stainless Steel

¹Other materials available on request.

²STL = Stellite #6.

MODEL 3150 / 3157 / 3159

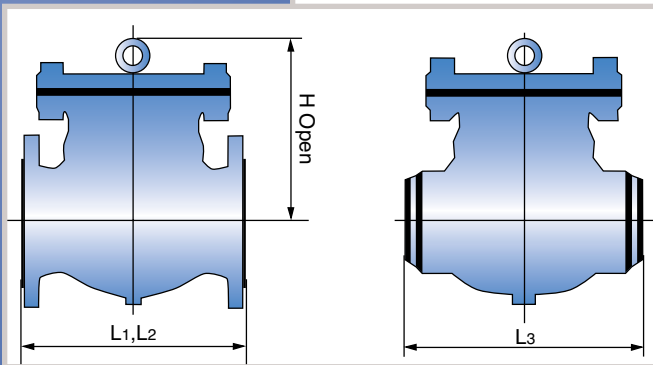

Cast steel swing check valve, horizontal or vertical lines, bolted cover, available in welded seat rings, designed according to API-600/ASME B16.34

DIMENSIONS

Face to Face	ASME B16.10
End Flange	ASME B16.5*
Buttweld	ASME B16.25
Rating	ASME Class 150

* 26" and larger are available with ASME B16.47 end flanges, either Series A or Series B (formerly MSS SP-44 and API 605).

CLASS 150

Dimensions in inches

Valve Size		1-1/2" 40mm	2" 50mm	2-1/2" 65mm	3" 80mm	4" 100mm	6" 150mm	8" 200mm	10" 250mm	12" 300mm	14" 350mm	16" 400mm	18" 450mm	20" 500mm	24" 600mm	30" 750mm	36" 900mm
Face to Face	L1: RF	6.50	8.00	8.50	9.50	11.50	14.00	19.50	24.50	27.50	31.00	34.00	38.50	38.50	51.00	60.00	77.00
	L2: RTJ	7.00	8.50	9.00	10.00	12.00	14.50	20.00	25.00	28.00	31.50	34.50	39.00	39.00	51.50	60.50	77.50
	L3: BW	6.50	8.00	8.50	9.50	11.50	14.00	19.50	24.50	27.50	31.00	34.00	38.50	38.50	51.00	60.00	77.00
Valve Open Height (H)		5.11	6.30	6.70	7.49	8.87	10.18	12.60	13.72	14.96	15.79	18.11	19.88	22.20	26.89	36.00	41.50
Weight (lbs.)	RF	33	38	48	68	110	203	299	430	628	926	1,102	1,411	1,720	3,285	5,077	8,160
	BW	28	31	38	56	95	183	266	284	572	804	980	1,160	1,495	2,945	4,315	7,010

CAST STEEL SWING CHECK VALVES

MODEL 3300 / 3307 / 3309

Cast steel swing check valve, horizontal or vertical lines, bolted cover, available in welded seat rings, designed according to API-600/ASME B16.34

DIMENSIONS

Face to Face	ASME B16.10
End Flange	ASME B16.5*
Buttweld	ASME B16.25
Rating	ASME Class 300

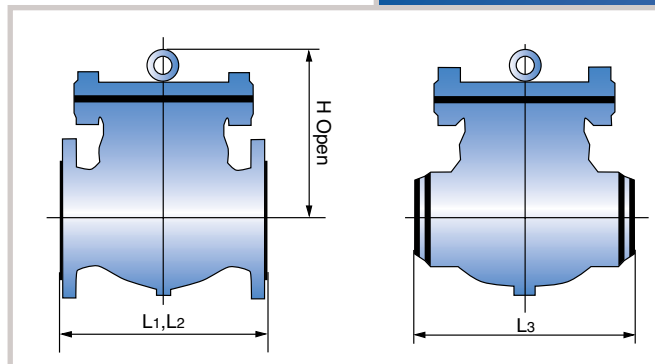

* 26" and larger are available with ASME B16.47 end flanges, either Series A or Series B (formerly MSS SP-44 and API 605).

Dimensions in inches

CLASS 300

Valve Size		2" 50mm	2-1/2" 65mm	3" 80mm	4" 100mm	6" 150mm	8" 200mm	10" 250mm	12" 300mm	14" 350mm	16" 400mm	18" 450mm	20" 500mm	24" 600mm	30" 750mm	36" 900mm
Face to Face	L1: RF	10.50	11.50	12.50	14.00	17.50	21.00	24.50	28.00	33.00	34.00	38.50	40.00	53.00	62.75	82.00
	L2: RTJ	11.13	12.13	13.33	14.63	18.13	21.63	25.13	28.63	33.63	34.63	39.13	40.75	53.88	63.75	83.00
	L3: BW	10.50	11.50	12.50	14.00	17.50	21.00	24.50	28.00	33.00	34.00	38.50	40.00	53.00	62.75	82.00
Valve Open Height (H)		6.30	7.44	7.83	8.94	10.94	12.68	15.08	17.13	20.08	20.51	22.52	24.76	28.03	37.00	42.99
Weight (lbs).	RF	56	72	108	160	299	406	657	916	1,503	1,649	2,097	2,494	4,500	5,850	10,500
	BW	43	55	88	102	240	317	525	750	1,241	1,305	1,803	2,150	3,870	5,020	9,450

MODEL 3600 / 3607 / 3609

Cast steel swing check valve, horizontal or vertical lines, bolted cover, available in welded seat rings, designed according to API-600/ASME B16.34

DIMENSIONS

Face to Face	ASME B16.10
End Flange	ASME B16.5
Buttweld	ASME B16.25
Rating	ASME Class 600

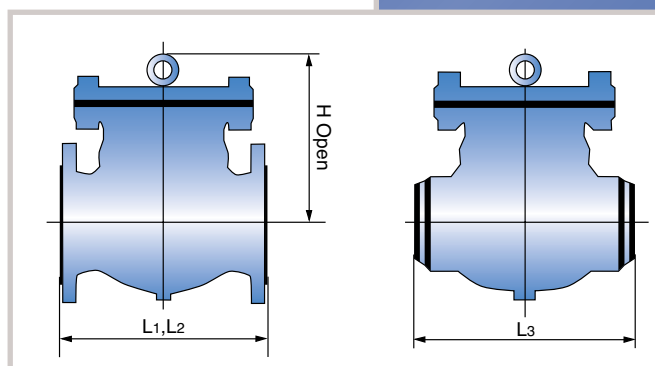

Dimensions in inches

CLASS 600

Valve Size		2" 50mm	3" 80mm	4" 100mm	6" 150mm	8" 200mm	10" 250mm	12" 300mm	14" 350mm	16" 400mm	18" 450mm	20" 500mm	24" 600mm
Face to Face	L1: RF	11.50	14.00	17.00	22.00	26.00	31.00	33.00	35.00	39.00	43.00	47.00	55.00
	L2: RTJ	11.63	14.13	17.13	22.13	26.13	31.13	33.13	35.13	39.13	43.13	47.25	55.38
	L3: BW	11.50	14.00	17.00	22.00	26.00	31.00	33.00	35.00	39.00	43.00	47.00	55.00
Valve Open Height (H)		7.38	8.25	10.06	12.94	14.31	18.25	19.13	22.50	26.00	28.00	31.00	34.00
Weight (lbs).	RF	71	130	247	474	849	1,351	1,918	2,068	2,976	4,451	5,269	6,634
	BW	66	110	223	364	686	1,081	1,605	1,693	2,469	3,802	4,443	5,137

CAST STEEL SWING CHECK VALVES

MODEL 3900 / 3907 / 3909

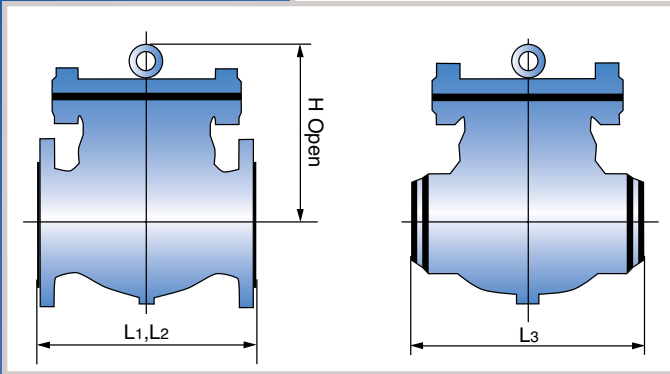

Cast steel swing check valve, horizontal or vertical lines, bolted cover, available in welded seat rings, designed according to API-600/ASME B16.34

DIMENSIONS

Face to Face	ASME B16.10
End Flange	ASME B16.5
Buttweld	ASME B16.25
Rating	ASME Class 900

CLASS 900

Dimensions in inches

Valve Size		2" 50mm	3" 80mm	4" 100mm	6" 150mm	8" 200mm	10" 250mm	12" 300mm	14" 350mm	16" 400mm	18" 450mm	20" 500mm	24" 600mm
Face to Face	L1: RF	14.50	15.00	18.00	24.00	29.00	33.00	38.00	40.50	44.50	48.00	52.00	61.00
	L2: RTJ	14.63	15.13	18.13	24.13	29.13	33.13	38.13	40.87	44.87	48.50	52.50	61.75
	L3: BW	14.50	15.00	18.00	24.00	29.00	33.00	38.00	40.50	44.50	48.00	52.00	61.00
Valve Open Height (H)		10.51	11.42	12.05	13.31	18.11	19.69	22.75	25.47	27.95	30.90	33.46	36.61
Weight (lbs).	RF	161	181	307	582	1,210	1,800	3,200	3,850	5,324	7,150	8,800	12,760
	BW	119	136	235	247	1,010	1,545	2,720	3,190	4,510	5,940	7,260	9,900

MODEL 31500 / 31507 / 31509

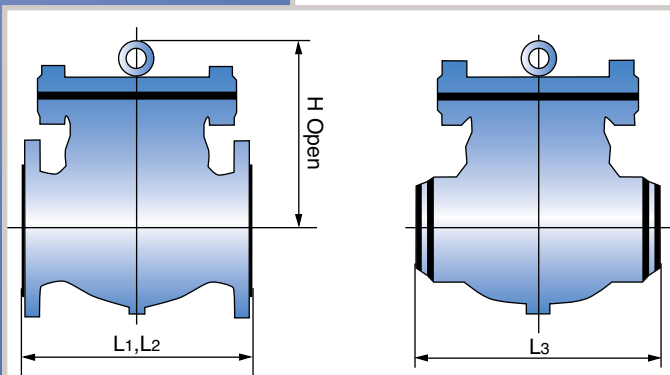

Cast steel swing check valve, horizontal or vertical lines, bolted cover, available in welded seat rings, designed according to API-600/ASME B16.34

DIMENSIONS

Face to Face	ASME B16.10
End Flange	ASME B16.5
Buttweld	ASME B16.25
Rating	ASME Class 1500

CLASS 1500

Dimensions in inches

Valve Size		2" 50mm	3" 80mm	4" 100mm	6" 150mm	8" 200mm	10" 250mm	12" 300mm	14" 350mm	16" 400mm	18" 450mm	20" 500mm	24" 600mm
Face to Face	L1: RF	14.50	18.50	21.50	27.75	32.75	39.00	44.50	49.50	54.50	60.50	65.50	76.50
	L2: RTJ	14.63	18.63	21.63	28.00	33.13	39.37	45.12	50.25	55.37	61.37	66.37	77.63
	L3: BW	14.50	18.50	21.50	27.75	32.75	39.00	44.50	49.50	54.50	60.50	65.50	76.50
Valve Open Height (H)		10.51	11.65	13.98	18.31	21.26	22.64	26.38	28.54	31.89	35.63	39.57	44.27
Weight (lbs).	RF	161	276	467	1,067	2,356	3,663	5,445	7,128	9,700	13,060	16,130	23,265
	BW	119	209	362	813	1,910	2,930	4,310	5,600	7,720	10,395	12,770	17,820

STANDARD PARTS & MATERIALS

NO.	PART NAME	STAINLESS STEEL				
		TYPE CF8M	TYPE CF8	TYPE CF3M	TYPE CF3	TYPE CN7M
1	BODY	A351-CF8M	A351-CF8	A351-CF3M	A351-CF3	A351-CN7M
2	BONNET	A351-CF8M	A351-CF8	A351-CF3M	A351-CF3	A351-CN7M
3	GATE	A351-CF8M	A351-CF8	A351-CF8M	A351-CF8	A351-CN7M
4	STEM	A479-316	A479-304	A479-316	A479-304	B473
5	HANDWHEEL	A197	A197	A197	A197	A197
6	GLAND FLANGE	A351-CF8 or 304	A351-CF8 or 304	A479-304	A479-304	A479-304
7	GLAND PROPER	A479-316	A479-304	A479-304	A479-304	A479-304
8	STEM NUT	A439-D2	A439-D2	A439-D2	A439-D2	A439-D2
9	HANDWHEEL NUT	A240-304	A240-304	A240-304	A240-304	A240-304
10	BONNET BOLT	A193-B8	A193-B8	A193-B8	A193-B8	A193-B8
11	GLAND EYEBOLT	A193-B8	A193-B8	A193-B8	A193-B8	A193-B8
12	GLAND EYEBOLT PIN	A479-304	A479-304	A479-304	A479-304	A479-304
13	BONNET NUT	A194-8	A194-8	A194-8	A194-8	A194-8
14	GLAND ADJUSTMENT NUT	A194-8	A194-8	A194-8	A194-8	A194-8
15	PACKING ¹	Teflon	Teflon	Teflon	Teflon	Teflon
16	GASKET ¹	Teflon	Teflon	Teflon	Teflon	Teflon
17	SET SCREW	A108-C/S 1020	A108-C/S 1020	A108-C/S 1020	A108-C/S 1020	A108-C/S 1020
18	NAME PLATE	Stainless Steel	Stainless Steel	Stainless Steel	Stainless Steel	Stainless Steel
19	THRUST WASHER	A479-410	A479-410	A479-410	A479-410	A479-410

¹Graphite on request to comply with API-603

MODEL 4150 / 4300

Cast stainless steel gate valve, outside screw and yoke, bolted bonnet, rising stem, non rising handwheel, flexible wedge for Class 150 on 3" and larger and 2" and larger for Class 300. Integral seat with design according to API-603, ASME B16.34.

DIMENSIONS

Face to Face	ASME B16.10
End Flange	ASME B16.5
Buttweld	ASME B16.25
Rating	ASME Class 150/300

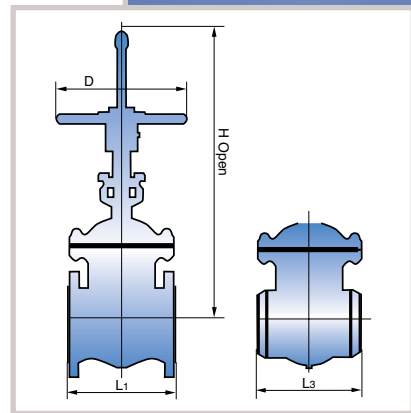

Dimensions in inches

Valve Size		1/2" 15mm	3/4" 20mm	1" 25mm	1-1/2" 40mm	2" 50mm	2-1/2" 65mm	3" 80mm	4" 100mm	6" 150mm	8" 200mm	10" 250mm	12" 300mm
Face to Face	L1: RF L3: BW	4.25	4.63	5.00	6.50	7.00	7.50	8.00	9.00	10.50	11.50	13.00	14.00
Valve Open Height (H)		7.48	7.83	9.17	11.22	13.11	15.08	16.69	20.86	28.74	36.85	43.86	53.89
Handwheel Diameter (D)		3.94	3.94	4.72	5.51	6.30	7.09	7.87	9.84	12.40	13.98	13.98	17.72
Weight (lbs).		4.85	6.20	9.94	19.20	28.00	38.85	48.00	75.50	126.00	213.00	291.40	434.90

Dimensions in inches

Valve Size		1/2" 15mm	3/4" 20mm	1" 25mm	1-1/2" 40mm	2" 50mm	2-1/2" 65mm	3" 80mm	4" 100mm	6" 150mm	8" 200mm	10" 250mm	12" 300mm
Face to Face	L1: RF L3: BW	5.50	6.00	6.50	7.50	8.50	9.50	11.13	12.00	15.88	16.50	18.00	19.75
Valve Open Height (H)		8.19	8.30	11.93	13.74	15.35	17.00	19.33	23.15	31.57	39.45	47.87	62.28
Handwheel Diameter (D)		3.93	3.93	4.72	7.09	7.87	7.87	8.82	9.84	13.98	15.75	17.72	19.69
Weight (lbs).		8.00	10.20	20.30	31.80	49.70	77.30	88.30	173.70	310.00	445.00	657.00	942.60

CLASS 150

CLASS 300

STANDARD PARTS & MATERIALS

NO.	PART NAME	STAINLESS STEEL				
		TYPE CF8M	TYPE CF8	TYPE CF3M	TYPE CF3	TYPE CN7M
1	BODY	A351-CF8M	A351-CF8	A351-CF3M	A351-CF3	A351-CN7M
2	BONNET	A351-CF8M	A351-CF8	A351-CF3M	A351-CF3	A351-CN7M
3	DISC	A351-CF8M	A351-CF8	A351-CF8M	A351-CF8	A351-CN7M
4	STEM	A479-316	A479-304	A479-316	A479-304	B473
5	HANDWHEEL	A197	A197	A197	A197	A197
6	GLAND FLANGE	A351-CF8 or 304	A351-CF8 or 304	A479-304	A479-304	A479-304
7	GLAND PROPER	A479-316	A479-304	A479-304	A479-304	A479-304
8	STEM NUT	A439-D2	A439-D2	A439-D2	A439-D2	A439-D2
9	HANDWHEEL NUT	A194-B	A194-B	A194-B	A194-B	A194-B
10	BONNET BOLT	A193-B8	A193-B8	A193-B8	A193-B8	A193-B8
11	GLAND EYEBOLT	A193-B8	A193-B8	A193-B8	A193-B8	A193-B8
12	GLAND EYEBOLT PIN	A479-304	A479-304	A479-304	A479-304	A479-304
13	BONNET NUT	A194-8	A194-8	A194-8	A194-8	A194-8
14	GLAND ADJUSTMENT NUT	A194-8	A194-8	A194-8	A194-8	A194-8
15	PACKING ¹	Teflon	Teflon	Teflon	Teflon	Teflon
16	GASKET ¹	Teflon	Teflon	Teflon	Teflon	Teflon
17	DISC NUT	A479-316	A479-304	A479-316L	A479-304L	B473
18	NAME PLATE	Stainless Steel	Stainless Steel	Stainless Steel	Stainless Steel	Stainless Steel

¹Graphite on request to comply with API-603.

MODEL 5150 / 5300

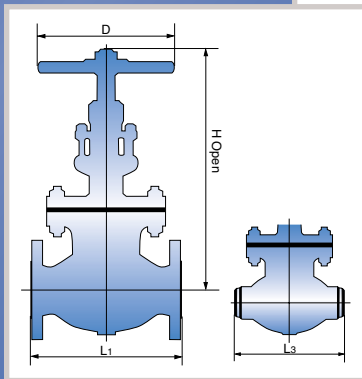

Cast stainless steel globe valve, outside screw and yoke, bolted bonnet, rising stem, non rising handwheel, swivel plug disc. Integral seat with design according to API-603, ASME B16.34.

DIMENSIONS

Face to Face	ASME B16.10
End Flange	ASME B16.5
Buttweld	ASME B16.25
Rating	ASME Class 150/300

Dimensions in inches

Valve Size		1/2" 15mm	3/4" 20mm	1" 25mm	1-1/2" 40mm	2" 50mm	2-1/2" 65mm	3" 80mm	4" 100mm	6" 150mm	8" 200mm
Face to Face	L1: RF L3: BW	4.25	4.63	5.00	6.50	8.00	8.50	9.50	11.50	16.00	19.50
Valve Open Height (H)		7.50	7.81	8.90	10.25	10.47	11.06	13.46	14.84	16.89	21.97
Handwheel Diameter (D)		3.94	3.94	5.51	7.09	7.09	8.87	8.82	11.02	13.98	15.75
Weight (lbs).		6.62	8.20	10.82	20.30	31.34	43.30	55.10	96.25	173.00	320.00

Dimensions in inches

Valve Size		1/2" 15mm	3/4" 20mm	1" 25mm	1-1/2" 40mm	2" 50mm	2-1/2" 65mm	3" 80mm	4" 100mm	6" 150mm	8" 200mm
Face to Face	L1: RF L3: BW	6.00	7.00	8.00	9.00	10.50	11.50	12.50	14.00	17.50	22.00
Valve Open Height (H)		7.28	7.64	8.82	10.51	12.99	13.93	15.08	17.44	22.32	27.40
Handwheel Diameter (D)		3.94	3.94	5.51	7.09	7.09	7.87	8.84	11.02	15.75	17.72
Weight (lbs).		8.80	11.50	20.70	32.20	58.50	80.00	119.20	171.00	292.00	574.00

CLASS 150

CLASS 300

CAST STAINLESS STEEL SWING VALVES

STANDARD PARTS & MATERIALS

NO.	PART NAME	STAINLESS STEEL				
		TYPE CF8M	TYPE CF8	TYPE CF3M	TYPE CF3	TYPE CN7M
1	BODY	A351-CF8M	A351-CF8	A351-CF3M	A351-CF3	A351-CN7M
2	COVER	A351-CF8M	A351-CF8	A351-CF3M	A351-CF3	A351-CN7M
3	DISC	A351-CF8M	A351-CF8	A351-CF8M	A351-CF8	A351-CN7M
4	HINGE	A351-CF8M	A351-CF8	A351-CF8M	A351-CF8	A351-CN7
5	HINGE ARM	A479-316	A479-304	A479-316	A479-304	B473
6	FLANGE PLUG	A479-316	A479-304	A479-316	A479-304	B473
7	BONNET BOLT	A193-B8	A193-B8	A193-B8	A193-B8	A193-B8
8	BONNET NUT	A194-8	A194-8	A194-8	A194-8	A194-8
9	DISC NUT	A194-8M	A194-8M	A194-B8M	A194-B8M	B473
10	DISC WASHER	A240-316	A240-316	A240-316	A240-316	B473
11	SPLIT PIN	A580-316	A580-316	A580-316	A580-316	B473
12	GASKET ¹	Teflon	Teflon	Teflon	Teflon	Teflon
13	PLUG GASKET ¹	Teflon	Teflon	Teflon	Teflon	Teflon
14	NAMEPLATE	Stainless Steel	Stainless Steel	Stainless Steel	Stainless Steel	Stainless Steel

¹Graphite on request to comply with API-603

MODEL 6150 / 6300

Cast stainless steel swing valve, horizontal or vertical lines, bolted cover, integral seat with design according to API-603, ASME B16.34.

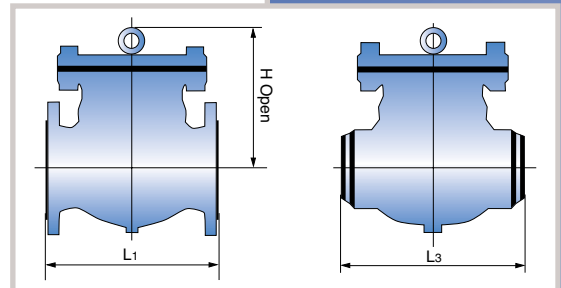

DIMENSIONS

Face to Face	ASME B16.10
End Flange	ASME B16.5
Buttweld	ASME B16.25
Rating	ASME Class 150/300

CLASS 150

Dimensions in inches

Valve Size		1/2"	3/4"	1"	1-1/2"	2"	2-1/2"	3"	4"	6"	8"	10"	12"
		15mm	20mm	25mm	40mm	50mm	65mm	80mm	100mm	150mm	200mm	250mm	300mm
Face to Face	L1: RF L3: BW	4.25	4.63	5.00	6.50	8.00	8.50	9.50	11.50	14.00	19.50	24.50	27.50
Valve Open Height (H)		3.26	3.50	4.00	4.72	5.43	6.10	6.30	7.91	9.76	11.53	12.99	13.94
Weight (lbs).		5.05	6.18	9.05	15.70	27.60	39.50	46.35	75.50	130.90	225.60	499.00	638.00

CLASS 300

Dimensions in inches

Valve Size		1/2"	3/4"	1"	1-1/2"	2"	2-1/2"	3"	4"	6"	8"	10"	12"
		15mm	20mm	25mm	40mm	50mm	65mm	80mm	100mm	150mm	200mm	250mm	300mm
Face to Face	L1: RF L3: BW	5.50	6.00	8.50	9.50	10.50	11.50	12.50	14.00	17.50	21.00	24.50	28.00
Valve Open Height (H)		3.66	3.78	4.41	4.96	5.98	6.46	6.93	7.32	10.31	12.28	13.98	15.47
Weight (lbs).		7.73	9.93	22.96	32.20	39.70	79.47	88.30	152.30	234.00	379.70	498.00	638.00

STANDARD API-600 PACKING AND GASKETS

GATE			GLOBE			CHECK		
PRESSURE CLASS/NPS	PACKING	GASKET	PRESSURE CLASS	PACKING	GASKET	PRESSURE CLASS	PACKING	GASKET
CLASS 150 2"– 12"	PILLAR No. 6610 & 6528	PILLAR No. 1200 Non-Circular	CLASS 150 All Sizes	PILLAR No. 6610 & 6528	PILLAR No. 2601	CLASS 150 All Sizes	N.A.	PILLAR No. 1200
CLASS 150 14"– 36"	PILLAR No. 6610 & 6528	PILLAR No. 1650-E Non-Circular						
CLASS 300/600 All Sizes	PILLAR No. 6610 & 6528	PILLAR No. 2601	CLASS 300/600 All Sizes	PILLAR No. 6610 & 6528	PILLAR No. 2601	CLASS 300/600 All Sizes	N.A.	PILLAR No. 2601
CLASS 900/1500 All Sizes	PILLAR No. 6610 & 6528	PILLAR No. 1500-S	CLASS 900/1500 All Sizes	PILLAR No. 6610 & 6528	PILLAR No. 1500-S	CLASS 900/1500 All Sizes	N.A.	PILLAR No. 1500-S

STANDARD API-603 PACKING AND GASKETS

GATE			GLOBE			CHECK		
PRESSURE CLASS/NPS	PACKING	GASKET	PRESSURE CLASS	PACKING	GASKET	PRESSURE CLASS	PACKING	GASKET
CLASS 150 All Sizes	PILLAR No. 6610 & 6528	PILLAR No. 6633	CLASS 150 All Sizes	PILLAR No. 6610 & 6528	PILLAR No. 1200	CLASS 150 All Sizes	N.A.	PILLAR No. 1200
CLASS 300 All Sizes	PILLAR No. 6610 & 6528	PILLAR No. 2601	CLASS 300 All Sizes	PILLAR No. 6610 & 6528	PILLAR No. 1200	CLASS 300 All Sizes	N.A.	PILLAR No. 1200

PILLAR NO.	DESCRIPTION
PILLAR No. 6610	Pure precut graphite ring. Also known as PILLARFOIL. Excellent performance in elevated temperatures to 600° C and pressure classes through ANSI 2500.
PILLAR No. 6528	Pure graphite impregnated non-asbestos fiber primarily used as a wiper. Excellent performance in elevated temperatures to 600° C and pressure classes through ANSI 2500.
PILLAR No. 6633	Metal foil inserted Pillar foil (pure graphite) sheet gasket.
PILLAR No. 1200	Corrugated metal gasket. Excellent for use in flat-faced flange facing designs. Both circular and non-circular designs.
PILLAR No. 1650E	Single metal jacketed non-asbestos fiber gasket treated with PILLARFOIL. This gasket provides excellent sealability even under low tightening pressure.
PILLAR No. 2601	Spiral wound Stainless Steel and PILLARFOIL gasket with inner ring for compression control. This gasket provides excellent gas sealability.
PILLAR No. 1500-S	Octagonal shaped soft metal ring. This design provides for excellent sealability for an RTJ design seal.

Sizes Available: 2" - 24"

Class: 150 & 300

Design Features

The dovetail groove feature in the seat ring holds the O-Ring seal in place while allowing it to expand or contract during service and still maintains the proper compression to provide uniform sealing.

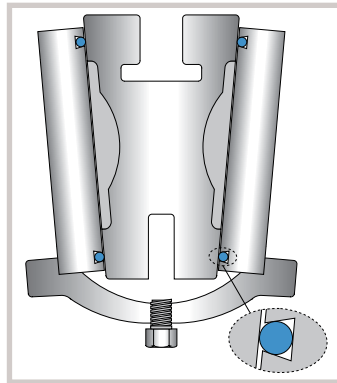

The precision ground metal to metal seats with the O-Ring feature as secondary seal provides dual seating and eliminates any media contamination.

A bleed plug is provided at position G to verify shut-off.

Fire Safe, Vapor Tight Shut-off

Should fire occur burning or damaging the O-Ring seal, metal to metal seats will provide an effective fire-safe shut-off.

Service Recommendations

GWC O-Ring Seal Block and Bleed Gate Valves are recommended for hard to hold services such as butane, kerosene, gasoline, propane, diesel oils, fuel oils, jet fuels, steam, air, natural gas, toluene, hydrogen, helium, and oxygen. Manifold tank farms, LPG areas, and airport fueling facilities provide excellent opportunities for savings with the *O-Ring Seal Gate Valves*. For effective double block and bleed service, the line media should be free of foreign matter and solids in suspension.

Seat Materials

Teflon is considered our standard. It is the most widely used elastomer because of its resistance to corrosive and abrasive conditions. We can also offer other materials. Seat insert materials should be specified along with actual service conditions when ordering.

Type Range

Teflon (PTFE)

Temperature Operating

-100° F + 400° F

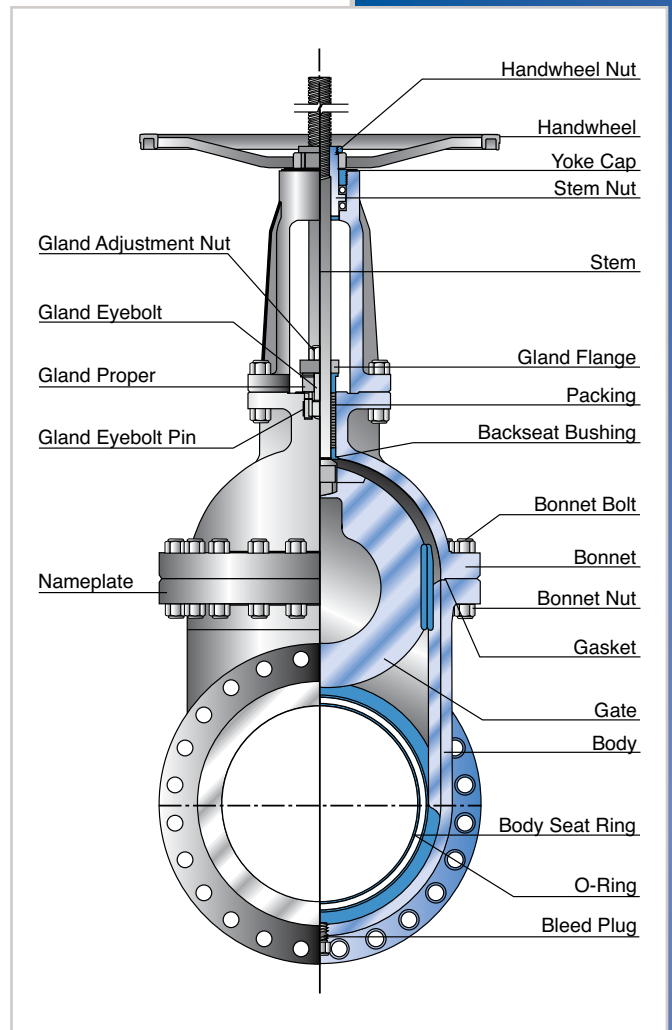

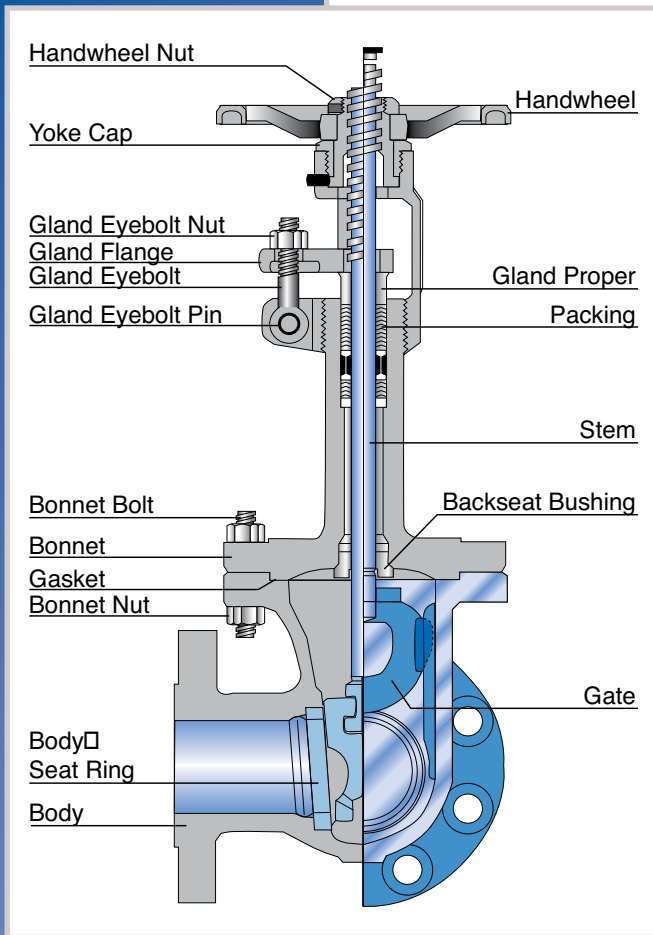

GWC Cryogenic Valves are manufactured to the latest edition of API Standard 600 and/or 603 and tested to API Standard 598.

APPLICATION & FUNCTION

During the processes of production, transportation, storage and usage of liquefied gases, countless technical problems can be experienced. GWC's cryogenic valves are designed to assure safety and reliability under these critical conditions.

All of GWC's cryogenic valves are thoroughly cleaned and degreased. Afterwards the end ports are sealed to prevent contamination. This process is performed in an approved and designated *clean room*.

BODY & BONNET

The design of the body and bonnet is calculated to achieve the most regular distribution of stress in all directions, as well as the minimum turbulence and resistance to flow.

The extended bonnet provides a gas column which thermally isolates the stem packing and stem nut from the extreme temperatures so they remain functional. Usually the customer specifies the column length.

The body-bonnet joint is bolted using applicable ASTM specified bolting for low temperature/ cryogenic conditions.

GASKET

We can supply any style of gasket required by our customer; however, we recommend gaskets that are oxygen compatible.

CLOSURES

GATE VALVES – All gates are fully guided to the seats. As standard, our valves are supplied with a stellite faced, solid flexible gate that has a tapered H cross-section. The flexible wedge is cast or machined with a circumferential groove to allow the seating surfaces to move independently and adjust to movement of the body seats.

GLOBE VALVES – The valve is normally supplied with the plug type disc. The disc rotates freely on the stem and incorporates a differential angle from that on the seat ring. This design provides the maximum assurance of shut off, is less likely to stick in the body seat and is considered the simplest design for field repair. Bottom guided discs are available.

CHECK VALVES – Each disc's seating surface is precision ground and mated to the seat ring for insurance of a positive shut off. The disc is bolted to the hinge arm and pinned to prevent disengagement during service.

KEL-F and other soft inserts are available upon request.

SEAT RING

Stellite faced seat rings are standard and provide excellent resistance to seizing and galling. KEL-F inserts are available when extremely tight shut-off is required. Our globe and check valves are supplied with KEL-F or other soft inserts as specified by the customer.

STEM

The stem connection to the wedge is a T-head design which is integral (without welding) with the stem. The T-head on NPS 8" and smaller valves are forged. The accuracy in the dimensions and finishes assure a long life with a perfect tightness in the packing area.

The stem-to-gate connection is designed to prevent the turning or the disengagement of stem from the wedge while the valve is in service.

Through calculations and extreme testing, the strength of the stem-to-gate connection has proven to exceed the strength of the stem at the root of its operating thread.

STEM PACKING

The stem packing is designed and arranged to ensure a maximum seal along the stem during operation or while at position. Our packings are NON-ASBESTOS types.

We can supply any style of packing required by our customer.

STEM NUT

The stem nut arrangement and design allows for the removal of the handwheel without allowing the stem and gate to drop into the closed position if the handwheel is removed while the valve is in the open position.

Ball bearings are provided in the stem nut arrangement of Class 150 valves from NPS 14", on Class 300 valves from NPS 12", on Class 600 valves from NPS 6", and on Class 900 and Class 1500 valves from NPS 2".

PACKING GLAND

The packing gland design is a two-piece, self-aligning type. The gland proper has a spherical head that rides within spherical joint of the gland flange. The gland proper has a shoulder, which restricts the complete entry into the stuffing box bore. This particular design assures a straight compression of the packing as the gland eyebolts are being equally adjusted, without injuring the stem.

HANDWHEELS

Handwheels are designed for easy operation and a comfortable grip. Our valves are also available with gearing, motor actuators or cylinder actuators for more demanding services.

END CONNECTIONS

Our standard production covers valves with:

- Flange ends with raised face (RF), flat face (FF) or ring type joint (RTJ) ends that conform to B16.5.
- Butt-welding (BW) ends that conform to B16.25.
- All face-to-face/end-to-end dimensions conform to B16.10.
- Other special end connections are supplied according to customer's requirements.

ACCESSORIES

Accessories such as gear operators, actuators, bypasses, locking devices, chainwheels, and many others are available to meet the customers requirements.

PRESSURE-TEMPERATURE RATINGS

STEEL, NICKEL & OTHER ALLOYS

COLD WORKING PRESSURE, psig													
Class	Temp °F	A216 WCB	A217 C5	A217 C12	A217 WC6	A217 WC9	A351 CF8	A351 CF8M	A351 CF3	A351 CF3M	A352 CN7M	A352 LCB	A352 LC3
		A105			A182 F11	A182 F22	A182 F304	A182 F316					A350 LF3
150	-20 to 100	285	290	290	290	290	275	275	275	275	230	265	290
	200	260	260	260	260	260	235	240	235	240	215	250	260
	300	230	230	230	230	230	205	215	205	215	200	230	230
	400	200	200	200	200	200	180	195	180	195		200	200
	500	170	170	170	170	170	170	170	170	170		170	170
	600	140	140	140	140	140	140	140	140	140		140	140
	650	125	125	125	125	125	125	125	125	125		125	125
	700	110	110	110	110	110	110	110	110	110			
	750	95	95	95	95	95	95	95	95	95			
	800	80	80	80	80	80	80	80	80	80			
	850	65 ^A	65	65	65	65	65	65	65	65			
	900	50 ^A	50	50	50	50	50	50	50	50			
	950	35 ^A	35	35	35	35	35	35	35	35			
	1000	20 ^A	20	20	20	20	20	20	20	20			
	1050		20 ^B	20 ^B	20 ^B	20 ^B	20 ^B	20 ^B	20 ^B	20 ^B			
	1100		20 ^B	20 ^B	20 ^B	20 ^B	20 ^B	20 ^B	20 ^B	20 ^B			
	1150		20 ^B	20 ^B	20 ^B	20 ^B	20 ^B	20 ^B	20 ^B	20 ^B			
	1200		20 ^B	20 ^B	20 ^B	20 ^B	20 ^B	20 ^B	20 ^B	20 ^B			
	1250							20 ^B	20 ^B	20 ^B			
	1300							20 ^B	20 ^B	20 ^B			
1350							20 ^B	20 ^B	20 ^B				
1400							20 ^B	20 ^B	20 ^B				
1450							15 ^B	20 ^B	20 ^B				
1500							10 ^B	15 ^B					
300	-20 to 100	740	750	750	750	750	720	720	720	720	600	695	750
	200	675	750	750	710	710	600	620	600	620	555	655	750
	300	655	730	730	675	675	530	560	530	560	525	640	730
	400	635	705	705	660	650	470	515	470	515		620	705
	500	600	665	665	640	640	435	480	435	480		585	665
	600	550	605	605	605	605	415	450	415	450		535	605
	650	535	590	590	590	590	410	445	410	445		525	590
	700	535	570	570	570	570	405	430	405	430			
	750	505	530	530	530	530	400	425	400	425			
	800	410	500	510	510	510	395	415	395	415			
	850	270 ^A	440	485	485	485	390	405		405			
	900	170 ^A	355	450	450	450	385	395		395			
	950	105 ^A	260	370	380	380	375	385		385			
	1000	50 ^A	190	290	225	270	325	368		368			
	1050		140	190	140	200	310	360		360			
	1100		105	115	95	115	260	325		325			
	1150		70	75			195	275		275			
	1200		45	50			155	205		205			
	1250						110	180		180			
	1300						85	140		140			
1350						60	105		105				
1400						50	75		75				
1450						35	60		60				
1500						25	40		40				
600	-20 to 100	1480	1500	1000	1425	1500	1440	1440	1440	1440	1200	1390	1500
	200	1350	1500	1000	1345	1430	1200	1240	1200	1240	1115	1315	1500
	300	1315	1455	970	1315	1355	1055	1120	1055	1120	1045	1275	1455
	400	1270	1410	940	1285	1295	940	1030	940	1030		1235	1410
	500	1200	1330	885	1210	1280	875	955	875	955		1165	1330
	600	1095	1210	805	1175	1210	830	905	830	905		1065	1210
	650	1075	1175	785	1135	1175	815	890	815	890		1045	1175
	700	1065	1135	755	1065	1135	805	865	805	865			1440
	750	1010	1065	710	1015	1065	795	845	795	845			
	800	825	995	675	975	1015	790	830	790	830			
	850	535 ^A	880	650	900	975	780	810		810			
	900	345 ^A	705	600	755	900	770	790		790			
	950	205 ^A	520	495	445	755	750	775		775			
	1000	105 ^A	385	390	275	535	645	725		725			
	1050		280	250	190	400	620	720		720			
	1100		205	150		225	515	645		645			
	1150		140	100			390	550		550			
	1200		90	70			310	410		410			
	1250				1500		220	365		365			
	1300						165	275		275			
1350						125	205		205				
1400						95	150		150				
1450						70	115		115				
1500						50	85		85				

A – Permissible, but not recommended for prolonged usage above about 800° F.

B – For welding end valves only, flanged end ratings terminate at 1000° F

PRESSURE-TEMPERATURE RATINGS

STEEL, NICKEL & OTHER ALLOYS

COLD WORKING PRESSURE, psig													
Class	Temp °F	A216	A217	A217	A217	A217	A351	A351	A351	A351	A352	A352	A352
		WCB	C5	C12	WC6	WC9	CF8	CF8M	CF3	CF3M	CN7M	LCB	LC3
		A105			A182	A182	A182	A182					A350
					F11	F22	F304	F316					LF3
900	-20 to 100	2220	2250	2250	2250	2250	2160	2160	2160	2160	1800	2085	2250
	200	2025	2250	2250	2135	2150	1800	1860	1800	1860	1670	1970	2250
	300	1970	2185	2185	2020	2030	1410	1540	1410	1540	1570	1915	2185
	400	1900	2115	2115	1975	1945	1410	1540	1410	1540		1850	2115
	500	1795	1995	1995	1925	1920	1310	1435	1310	1435		1745	1995
	600	1640	1815	1815	1815	1815	1245	1355	1245	1355		1600	1815
	650	1610	1765	1765	1765	1765	1225	1330	1225	1330		1570	1765
	700	1600	1705	1705	1705	1705	1210	1295	1210	1295			
	750	1510	1595	1595	1595	1595	1195	1270	1195	1270			
	800	1235	1490	1525	1525	1525	1180	1245	1180	1245			
	850	805 ^A	1315	1460	1460	1460	1165	1215		1215			
	900	515 ^A	1060	1350	1350	1350	1150	1180					
	950	310 ^A	780	1110	1130	1130	1125	1160					
	1000	155 ^A	575	875	670	805	965	1090					
	1050		420	565	410	595	925	1080					
	1100		310	340	290	340	770	965					
	1150		205	225			585	825					
	1200		135	155			465	620					
	1250						330	545					
	1300						245	410					
1350						185	310						
1400						145	225						
1450						105	175						
1500						70	125						
1500	-20 to 100	3705	3750	3750	3750	3750	3600	3600	3000	3600	3000	3470	3750
	200	3375	3750	3750	3560	3580	3000	3095	2640	3095	2785	3280	3750
	300	3280	3640	3640	3365	3385	2640	2795	2350	2795	2615	3190	3640
	400	3170	3530	3530	3290	3240	2350	2570	2185	2570		3085	3530
	500	2995	3325	3325	3210	3200	2185	2390	2075	2390		2910	3325
	600	2735	3025	3025	3025	3025	2075	2255	2040	2255		2665	3025
	650	2685	2940	2940	2940	2940	2040	2220	2015	2220		2615	2940
	700	2665	2840	2840	2840	2840	2015	2160	1990	2160			
	750	2520	2660	2660	2660	2660	1990	2110	1970	2110			
	800	2060	2485	2540	2540	2540	1970	2075		2075			
	850	1340 ^A	2195	2435	2435	2435	1945	2030		2030			
	900	860 ^A	1765	2245	2245	2245	1920	1970					
	950	515 ^A	1305	1850	1885	1885	1870	1930					
	1000	260 ^A	960	1460	1115	1340	1610	1820					
	1050		705	945	685	995	1545	1800					
	1100		515	565	480	565	1285	1610					
	1150		345	380			980	1370					
	1200		225	260			770	1030					
	1250						550	910					
	1300						410	685					
1350						310	515						
1400						240	380						
1450						170	290						
1500						120	205						
2500	-20 to 100	6170	6250	6250	6250	6250	6000	6000	6000	6000	5000	5785	6250
	200	5625	6250	6250	5930	5965	5000	5160	5000	5160	4640	5470	6250
	300	5470	6070	6070	5605	5640	4400	4660	4400	4660	4360	5315	6070
	400	5280	5880	5880	5485	5400	3920	4280	3920	4280		5145	5880
	500	4990	5540	5540	5350	5330	3640	3980	3640	3980		4850	5540
	600	4560	5040	5040	5040	5040	3460	3760	3460	3760		4440	5040
	650	4475	4905	4905	4905	4905	3400	3700	3400	3700		4355	4905
	700	4440	4730	4730	4730	4730	3360	3600	3360	3600			
	750	4200	4430	4430	4430	4430	3320	3520	3320	3520			
	800	3430	4145	4230	4230	4320	3280	3460	3280	3460			
	850	2230 ^A	3660	4060	4060	4060	3240	3320		3320			
	900	1430 ^A	2945	3745	3745	3745	3200	3280					
	950	860 ^A	2170	3085	3145	3145	3120	3220					
	1000	430 ^A	1660	2430	1860	2230	2685	3030					
	1050		1170	1570	1145	1660	2570	3000					
	1100		860	945	800	945	2145	2685					
	1150		570	630			1630	2285					
	1200		370	430			1285	1715					
	1250						915	1515					
	1300						685	1145					
1350						1515	860						
1400						400	630						
1450						285	485						
1500						200	345						

A – Permissible, but not recommended for prolonged usage above about 800° F.

B – For welding end valves only, flanged end ratings terminate at 1000° F

Scope

These terms and conditions apply to all GWC valve products, and supersedes all previously published terms and conditions.

Hereafter, GWC Valve International, Inc. shall be referred to as GWC.

Special terms and conditions printed on a buyer's order will only apply insofar as they conform to the terms and conditions detailed on these pages. Terms and conditions of an order that change or modify those on this sheet shall not be binding on GWC.

Approval

All quotations, contracts, orders, or agreements are subject to approval and/or acceptance by the main office of GWC.

We reserve the right to correct clerical or stenographic errors in quotations, orders, invoices, and other contracts, agreements, or documents.

Prices

Possession of price lists will not be accepted by GWC as an obligation, or offer to sell the goods listed therein to anyone.

All prices contained therein are subject to change without notice, and supersede all previous lists. All orders will be invoiced at prices in effect at the time of shipment unless quoted in writing.

Changes

Orders cannot be cancelled or specifications be changed without the consent of GWC, and then only in terms indemnifying GWC against loss.

Quotations

Goods quoted F.O.B. our service center are subject to prior sale. Prices quoted are valid only for the duration indicated in the quotation. Quoted prices supersede all previous prices, quotations, or contracts, and are subject to change without notice.

Cancellations

Orders placed with us cannot be cancelled without our prior written consent. A cancellation charge will be applicable as outlined in our quotation.

Claims

All claims for shortages, corrections, or deductions must be made within 10 days after receipt of goods. Responsibility for goods lost or damaged in transit rests with carrier, and claims should be filed with the carrier by the consignee. Delivery of material to a common carrier shall be considered delivery to the buyer, and shall be at the buyers risk thereafter.

Delivery Delays

We assume no responsibility for delays in delivery, or defaults resulting from strikes, work stoppages, fires, floods, accidents, war, inability to obtain materials, or any other cause unavoidable and beyond our control.

Taxes

GWC quotations and/or contracts do not include any municipal, state, or federal sales, excise, use occupational, or other taxes, and any such tax, if paid by us will be charged to the purchaser.

Catalog Illustrations

Catalog illustrations are actual representations of a certain size of each product line, but do not necessarily represent all sizes in details. We reserve the right to institute changes in materials, designs, and specifications without notice in keeping with our policy of continuing product improvement.

Catalog Weights

Catalog weights represent average weights of products and are in no sense guaranteed.

Returns

See Return Goods Policy on next page.

Special Orders

Orders for special goods must be in writing and accompanied with detailed prints and/or sets of specifications, unless specifications on the orders are definite and complete. Orders will not be entered with the factory unless this is adhered to. Cancellation charges will be as outlined in our quotations.

Freight Terms

All shipments are F.O.B. our service centers. See current bulletin for freight allowance.

Warranty

See warranty on reverse side

RETURN GOODS POLICY

This policy supersedes all other policies for return goods.

I. Goods returned at customers request:

A. Material must be:

1. Of our manufacture.
2. In clean, new and saleable condition. It must have been stored inside out of the weather.
3. Shipped from one of our service centers within the 12 calendar months preceding the request for return, and the return will not cause inventory to exceed maximum allowable levels.
4. Personally inspected by a GWC representative prior to its return.
5. Special or non-standard items are non-returnable.

B. Return shipments must be prepaid.

C. Credit will be allowed at invoice price, less 25% handling cost, and less any freight paid by GWC.

D. A Return Goods Card must be furnished by a GWC representative after inspection of the material, and must be returned with the shipment.

E. Shipments received without a Return Goods Authorization Card will be refused. Customer will be responsible for any storage and/or return freight.

F. Material returned which is not of GWC manufacture, not in clean and saleable condition, or not authorized for return will be returned to the customer freight collect.

II. Goods returned because of an error by GWC.

A. Material must be in a clean, new, saleable condition.

B. Return shipment should be made freight collect.

C. Full credit will be allowed.

D. Customer must receive Return Goods authorization prior to the return of the material. Return Goods Authorization Card must accompany shipment. Shipments received without Return Goods Authorization Card will be refused. Return Goods Authorization Card should be attached to the packing list.

All requests to return material to GWC Valve International, Inc. must be submitted in writing to our National Sales Manager for authorization.

WARRANTY

GWC Valve International, Inc. warrants each product sold, if the products are of our manufacture, against defects in material and workmanship under normal use and service for a period of one year after date of shipment.

This warranty is made to the buyer only, and does not extend to any other party. The obligation of GWC Valve International, Inc. under this warranty is limited to: (a) replacement of any part or parts proven defective in material or workmanship, (b) repair of the product F.O.B. the factory or service center, (c) refund of the purchase price. In the case of product or parts not wholly of GWC's manufacture, GWC's liability under this warranty shall be limited to the extent of GWC's recovery from the manufacturer of such parts under its warranty to GWC. This warranty does not extend to any claims for labor, consequential damages, down time, or any other loss, damage, or expense of any kind arising out of the defect. We do not allow claims for unauthorized repairs, labor, or material. We are not responsible for loss of use, personal injury, lost profits, or any other damages whatsoever in connection with the warranties set forth.

No warranty shall apply to any product which has been modified or changed in design or function after leaving GWC's facilities or which is misused or operated beyond its design capabilities, or used for other than its intended purpose. Purchasers of GWC products should consult knowledgeable advisors in the selection of product type and material of construction for their specific use. The buyer assumes all risk of this selection.

The buyer shall permit GWC or its authorized representative to inspect the product so that it may determine its obligation. GWC shall be entitled to the return of the defective product or parts. Buyer must notify GWC promptly upon discover of any claimed defect.

No material may be returned without first obtaining written permission from GWC Valve International, Inc.

USA HEADQUARTERS

**GWC Valve International, Inc.
4301 Yeager Way
Bakersfield, CA 93313**

OVERSEAS DIVISIONS

**GWC Valve Europe Limited
Germany
An der Huelsebeeke 1
D-31547 Rehburg-Loccum**

**GWC Valve Middle East FZC
P.O. Box 8885
SAIF Zone
Sharjah**

MANUFACTURING DIVISIONS

**GWC Valve Manufacturing
(Shanghai) Co. Ltd.
No. 3600 Jihe Road
Huaxin Town, Qingpu District
Shanghai, 201708
People's Republic of China**

**GWC Valve Manufacturing
(Yancheng) Co. Ltd
No. 6 Juheng Rd,
Yancheng Economic Development
Zone, Jiangsu, 224007
People's Republic of China**



Group of Companies