



pulsar[™]

Pulse Burst Radar Level Transmitter

DESCRIPTION

The Pulsar[™] Radar transmitter is the latest generation of loop-powered, 24 VDC, level transmitters. It has lower power consumption, faster response time and is easier to use than most loop-powered radar transmitters.

This latest entry into the radar level measurement field is designed to provide unparalleled performance and ease of use. Pulsar non-contact radar is the perfect compliment to the Magnetrol Eclipse[®] Guided Wave Radar. These transmitters offer the ultimate solution to the vast majority of process level applications.

TECHNOLOGY

The Pulsar Radar transmitter is based on pulse burst radar technology together with equivalent time sampling circuitry. Short bursts of 5.8 or 6.3 GHz microwave energy are emitted and subsequently reflected from the liquid level surface. Distance is calculated by the equation $D = \text{Transit time (round-trip)}/2$. Liquid level is then calculated by applying the tank height value.

APPLICATIONS

MEDIA: Liquids and slurries; hydrocarbons to water based media (dielectric 1.7–100)

VESSELS: Most process or storage vessels up to rated temperature and pressure. Pits and pumps as well as non-metallic tanks such as plastic, glass-lined and concrete.

CONDITIONS: Virtually all level measurement and control applications including process conditions exhibiting varying specific gravity and dielectric, visible vapors, high fill/empty rates, turbulence, low to moderate foam and buildup.



FEATURES

- Two-wire, 24 VDC loop-powered level transmitter
- PACTware PC Program using HART communication for advanced configuration and troubleshooting. (see bulletin 59-101)
- Performance not process dependent (changing specific gravity and dielectric have no effect)
- 5.8/6.3 GHz operating frequency offers superior performance in the tougher applications of turbulence, foam, and heavy vapors
- False Target setup is simple, intuitive and effective
- Will reliably track extremely rapid rate of change up to 180 inches (450 cm)/minute
- Antenna designs to +400° F (+204° C), 750 psig (51.7 bar)
- Range up to 65 feet (20 meters)
- Quick connect/disconnect antenna coupling allows vessel to remain sealed (patent pending)
- Extremely low output at antenna: < .01 mW (avg), < 2 mW (max); hundreds of times less than a cell phone
- Safety Integrity Level (SIL) value of 1

APPLICATIONS

PULSE BURST RADAR

STORAGE AND INTERMEDIATE HOLDING TANKS

CONDITIONS – Calm Surfaces

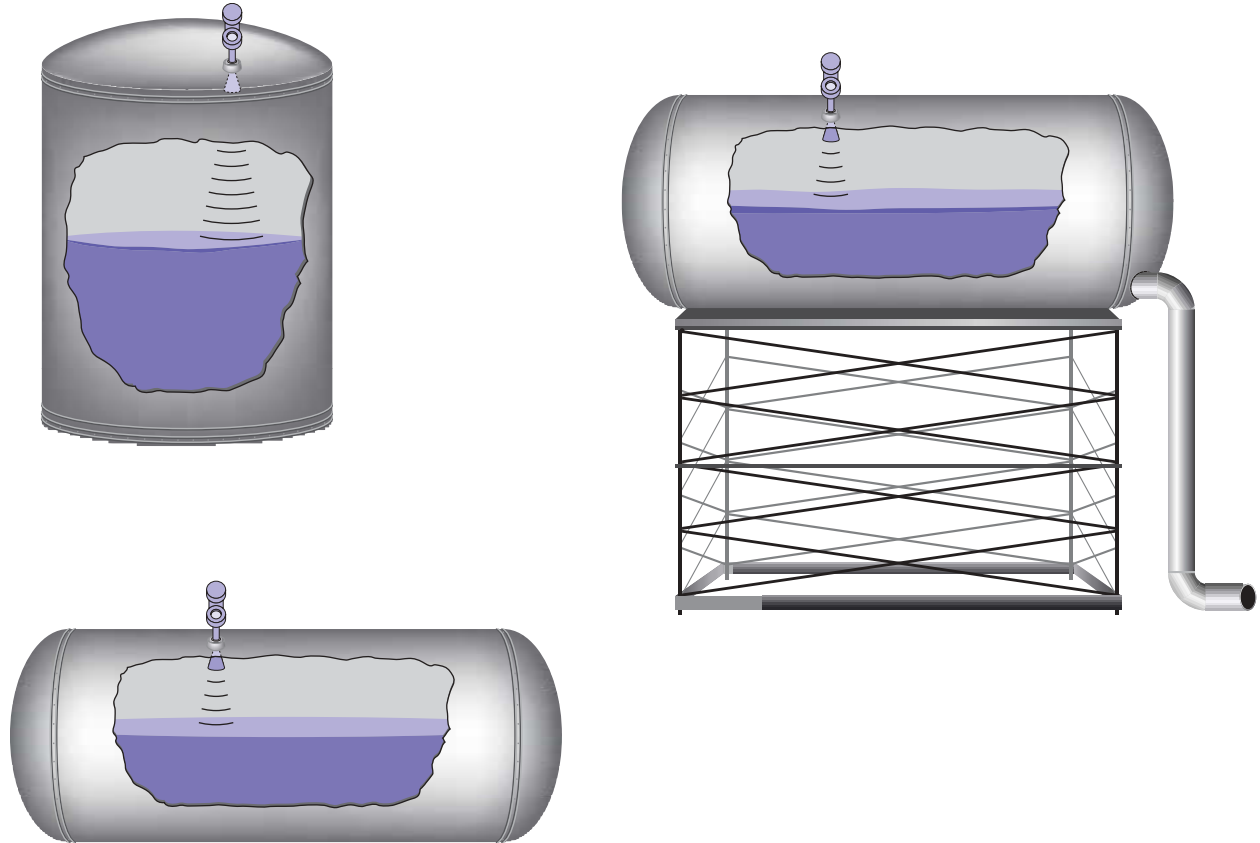

REACTORS

CONDITIONS – Turbulence and Foam

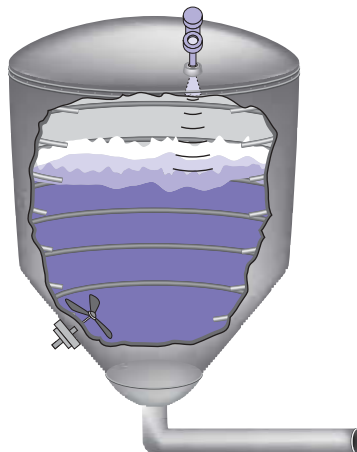

APPLICATIONS

PULSE BURST RADAR

MIXERS AND BLENDING VESSELS

CONDITIONS – Turbulence, Foam, and Changing Dielectric

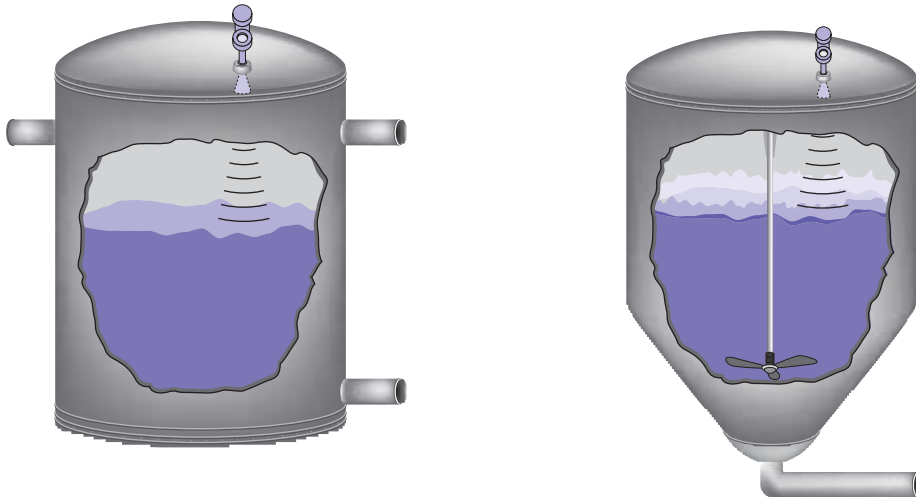

SUMPS

CONDITIONS – Turbulence, Foam, and Changing Dielectric

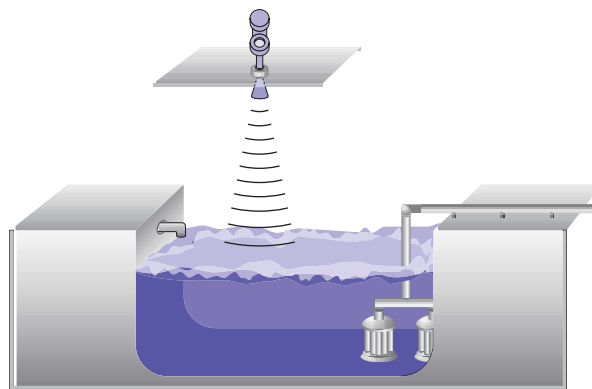

CHAMBERS AND BYPASS

USE ECLIPSE® GUIDED WAVE RADAR

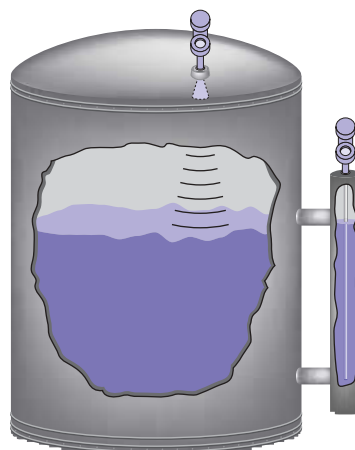

TECHNOLOGY

PULSE BURST RADAR

Pulsar is a top-mounted, downward-looking pulse burst radar operating at 5.8 GHz (Europe) or 6.3 GHz (North America). Unlike true pulse devices (Eclipse Guided Wave Radar) which transmit a single, sharp (fast rise-time) waveform of wide-band energy (Figure 1), Pulsar emits short bursts of 5.8 or 6.3 GHz energy (Figure 2) and measures the transit time of the signal reflected off the liquid surface.

Distance is calculated utilizing the equation Distance equals the Speed of light multiplied by the transit time divided by two ($Distance = C \times Transit\ Time / 2$), then developing the level value by factoring in tank height and sensor offset information (Figure 3). The exact reference point for distance and level calculations is the sensor reference point (bottom of an NPT thread, top of a BSP thread, or face of a flange).

The exact level measurement is extracted from false target reflections and other background noise via the use of sophisticated signal processing. The new Pulsar circuitry is extremely energy efficient so no duty cycling is necessary to accomplish effective measurement. For this reason Pulsar can track high rates of change (180 inches [450 cm] per minute) that were heretofore impossible with existing loop-powered radar transmitters.

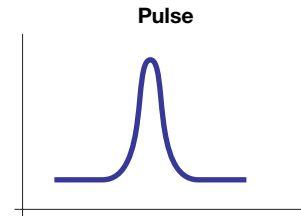

Figure 1

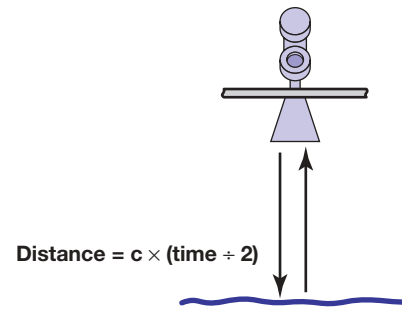
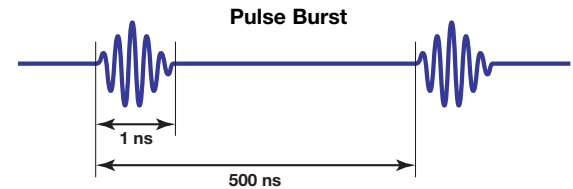

Figure 2

EQUIVALENT TIME SAMPLING

ETS, or Equivalent Time Sampling, is used to measure the high speed, low power EM (electromagnetic) energy. ETS is a critical key in the application of Radar to vessel level measurement technology. The high speed EM energy (1000 ft/ μ s) is difficult to measure over short distances and at the resolution required in the process industry. ETS captures the EM signals in real time (nanoseconds) and reconstructs them in equivalent time (milliseconds), which is much easier to measure with today's technology.

ETS is accomplished by scanning the vessel to collect thousands of samples. The round-trip event on a 65 foot (20 meter) tank takes only 133 nanoseconds in real time. After it is reconstructed in equivalent time it measures 200 milliseconds.

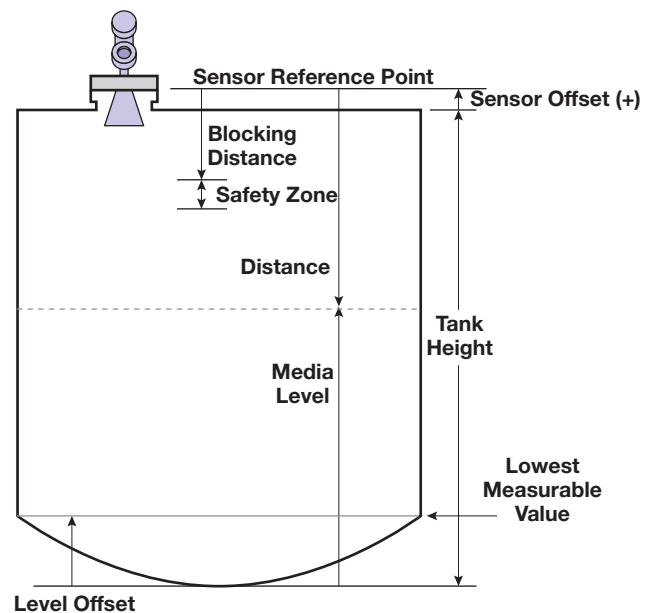

Figure 3

OPERATIONAL CONSIDERATIONS

Radar applications are characterized by three basic conditions:

- Dielectric
- Distance (measuring range)
- Disturbances (turbulence, foam, false targets, multiple reflections and rate of change)

The Pulsar Radar transmitter is offered with four antenna configurations:

- Polypropylene Dielectric Rod
- TFE Dielectric Rod
- 4" (100 mm) Horn
- 6" (150 mm) Horn

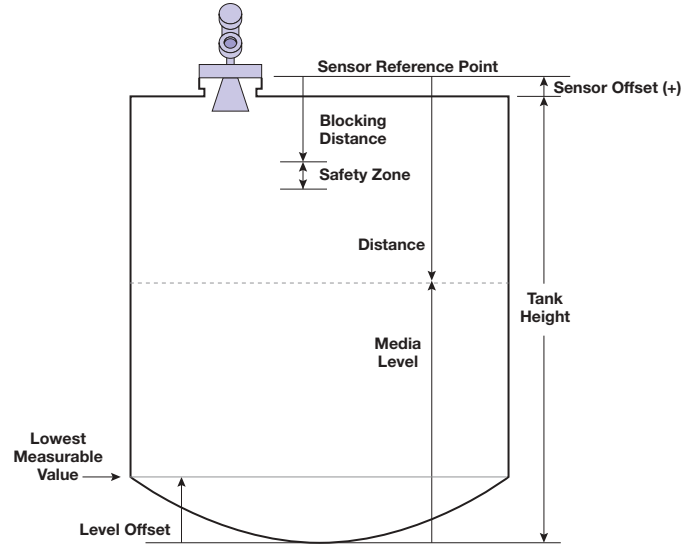

Figure 4

Maximum measuring range (distance) is calculated as Tank Height + Sensor Offset. Refer to Figure 4. It is measured from the sensor reference point (bottom of NPT thread, top of BSP thread, or face of flange).

Ideally the 6" (150 mm) horn antenna should be used to ensure the best possible performance in all operational conditions. Since that is impractical, other antennas are available. The chart shows the maximum measuring range of each antenna based on dielectric and turbulence. Refer to Figure 5.

Although it is theoretically possible to measure a liquid level on the antenna, noise and media buildup drastically decrease reliable measurement. Liquid should not be allowed closer than 2 inches (50 mm) from the bottom of the antenna. Refer to Figure 6.

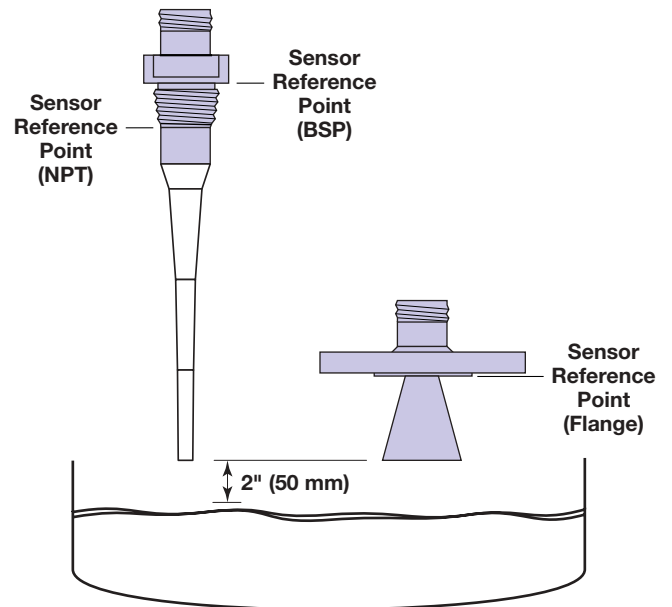

Figure 6

MAXIMUM DISTANCE feet (meters)

Dielectric	Turbulence	Dielectric Rod (1½")	4" Horn	6" Horn
1.7-3.0	None	35 (10.7)	40 (12.2)	45 (13.7)
	Light, < 0.5"	28 (8.5)	33 (10.1)	37 (11.3)
	Moderate, < 1.0"	21 (6.4)	26 (7.9)	29 (8.8)
	Heavy, > 1.0"	15 (4.6)	17 (5.2)	20 (6.1)
3.0-10.0	None	50 (15.2)	55 (16.8)	60 (18.3)
	Light, < 0.5"	40 (12.2)	44 (13.4)	48 (14.6)
	Moderate, < 1.0"	30 (9.1)	33 (10.1)	35 (10.7)
	Heavy, > 1.0"	20 (6.1)	22 (6.7)	25 (7.6)
10.0-100	None	65 (20)	65 (20)	65 (20)
	Light, < 0.5"	52 (15.8)	52 (15.8)	53 (16.2)
	Moderate, < 1.0"	39 (11.9)	39 (11.9)	41 (12.5)
	Heavy, > 1.0"	25 (7.6)	27 (8.2)	30 (9.1)

Figure 5

MOUNTING

The Pulsar Radar transmitter can be mounted to a vessel using a variety of process connections. Generally either a threaded or flanged connection is used.

LOCATION

Ideally the Radar transmitter should be mounted $\frac{1}{2}$ radius from center providing an unobstructed signal path to the liquid surface where it should illuminate (with microwave energy) the largest possible surface area. Do not install in center of tank top or within 18 inches (45 mm) of tank wall. Tank walls may produce reflections that must be minimized during field configuration (Orientation). Refer to Figure 7.

BEAM ANGLE

The various antenna designs exhibit different beam patterns. Figure 9 shows the beam angles for all Pulsar antennas. Ideally the beam pattern should illuminate the maximum liquid surface with a minimum striking other objects in the vessel including the tank wall. Use these drawings to determine the optimum installation location.

OBSTRUCTIONS

Almost any object that falls within the beam pattern will cause reflections that may be misinterpreted as a false liquid level. Although Pulsar has a powerful False Target Rejection routine, all possible precautions should be taken to minimize false target reflections with proper installation and orientation. Refer to Figures 8 & 9.

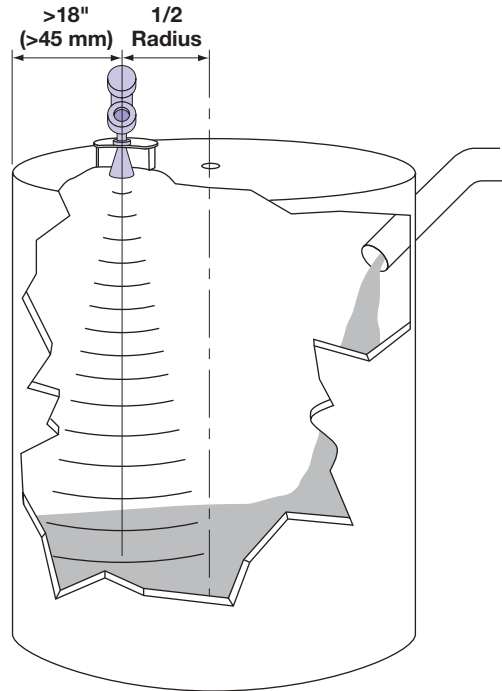

Figure 7

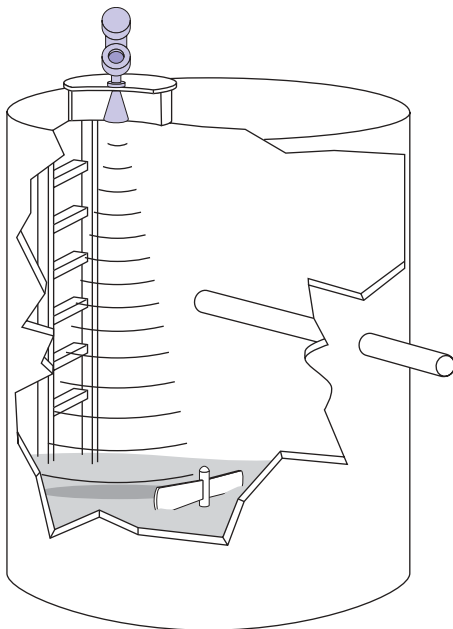
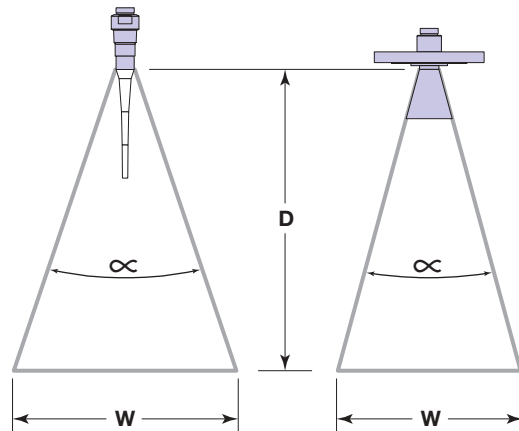

Figure 8



Antenna	Beam Spread, W @-3dB; ft (m)		
	Dielectric Rod	4" Horn	6" Horn
Beam Angle (∞)	25°	25°	17°
Distance, D			
10 (3)	4.5 (1.37)	4.5 (1.37)	3.0 (0.91)
20 (6)	8.9 (2.71)	8.9 (2.71)	6.0 (1.83)
30 (9)	13.3 (4.05)	13.3 (4.05)	9.0 (2.74)
40 (12)	17.8 (5.43)	17.8 (5.43)	12.0 (3.66)
50 (15)	22.2 (6.77)	22.2 (6.77)	15.0 (4.57)
60 (18)	26.6 (8.11)	26.6 (8.11)	18.0 (5.49)
65 (20)	28.9 (8.81)	28.9 (8.81)	19.5 (5.95)

Figure 9

MOUNTING

NOZZLES

Improper installation in a nozzle creates “ringing” which will adversely affect measurement. The antenna should always be mounted so the active section of the antenna is a minimum of 0.5" (12 mm) below the nozzle (be sure to include any nozzle dimension *inside* the vessel). Refer to Figure 10. Antenna extensions are offered to allow the Pulsar transmitter to work reliably in nozzles with “L” dimensions of 1" (25 mm), 4" (100 mm), 8" (200 mm) or 12" (300 mm). Standard antennas are shown below for reference.

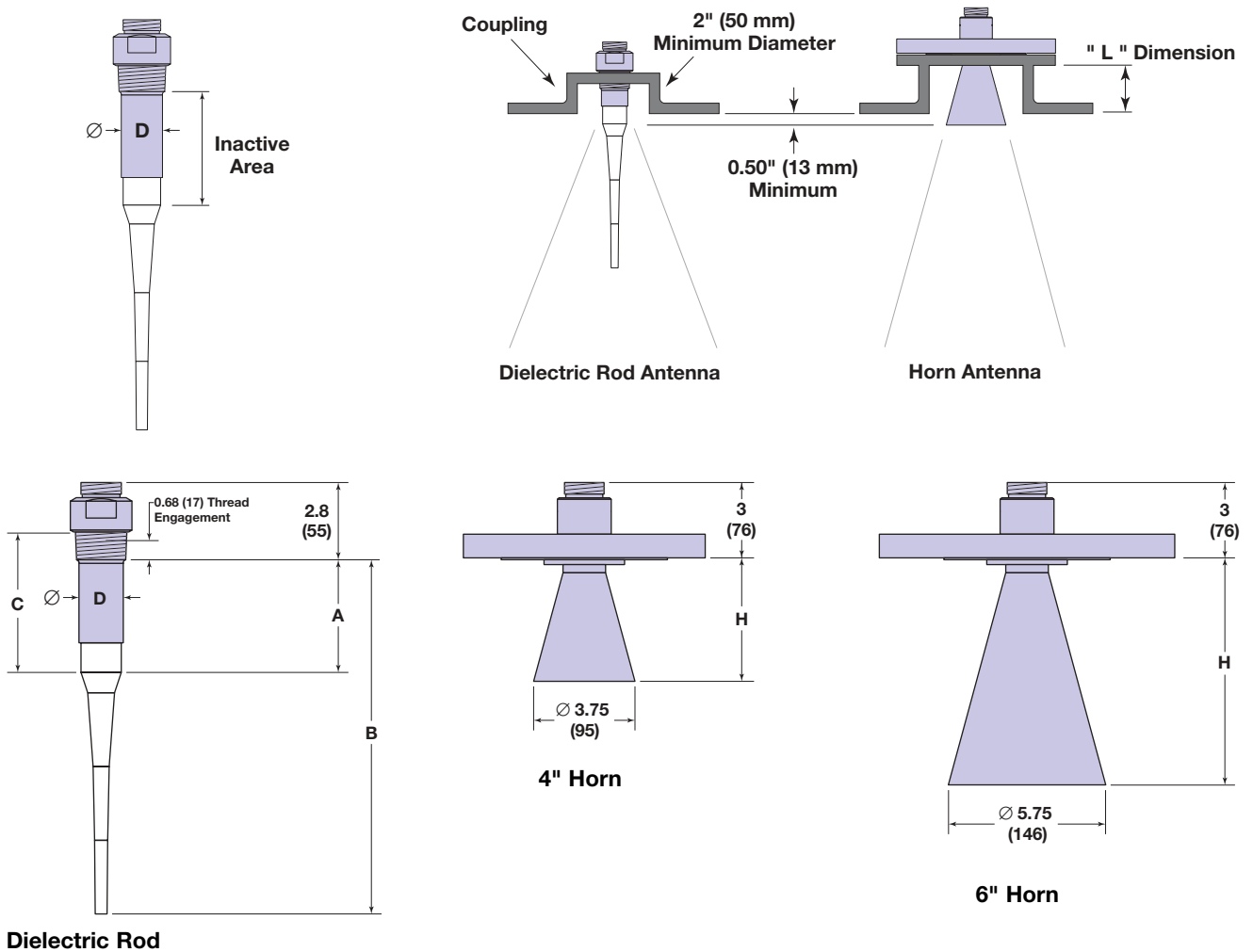

Model #	Antenna Extension (maximum "L" dimension)	DIELECTRIC RODS			HORNS		Antenna Extension O.D. Dimension D	
		All	All	BSP	4"	6"	TFE Rod	PP Rod
8th Digit		Dim A	Dim B	Dim C	Dim H	Dim H		
0	1" (25)	2.3 (58)	11.1 (282)	3.1 (79)	↓	↓	Ø 1.625 (41)	
1	4" (100)	5.1 (130)	14.0 (356)	5.9 (150)	4.6 (117)		Ø 1.50 (38)	
2	8" (200)	9.1 (231)	18.0 (457)	9.9 (251)	8.4 (213)	8.3 (211)		
3	12" (300)	13.1 (333)	22.0 (559)	13.9 (353)	12.4 (315)	12.4 (315)		Ø 1.625 (41)

Figure 10

MOUNTING

ORIENTATION

The Pulsar transmitter utilizes a linearly polarized, microwave beam that can be rotated to improve its performance. Proper orientation can minimize unwanted target reflections, decrease sidewall reflections (multipath) and maximize direct reflections from the liquid surface. The index mark located on the side of the launcher is oriented in the same direction as the polarization. Refer to Figure 10.

The index mark is also present for reference (1 dot: GP/IS or 2 dots: XP). The launcher is considered to be at 0° when the index mark is closest to the tank wall.

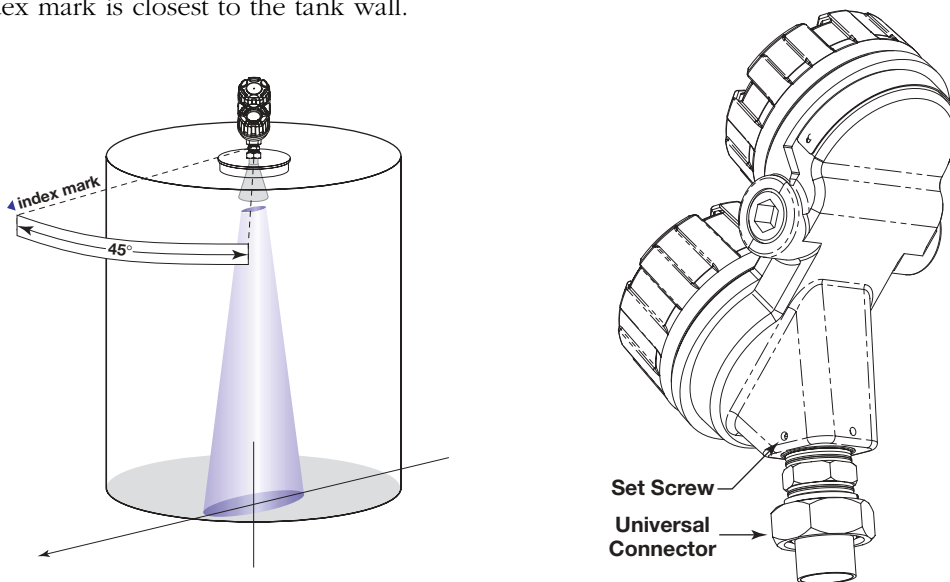

Figure 11

PROBLEMATIC APPLICATIONS

GUIDED WAVE RADAR ALTERNATIVE

Some applications can be problematic for Pulse Burst Radar. The following are examples of when Guided Wave Radar is recommended.

- Extremely low dielectric media ($\epsilon_r < 2.0$)
- Stillwells, standpipes, bridles, cages, and bypass columns.
- Very weak reflections from the liquid surface—particularly during turbulence can cause poor performance.
- Tanks heavily cluttered with false targets (mixers, pumps, ladders, pipes, etc.)
- During times of very low liquid levels of low dielectric media, the metal tank bottom may be detected deteriorating performance.
- Foam can either absorb or reflect the microwave energy depending upon the depth, dielectric, density and wall thickness of the bubbles. Due to typical variations in the amount (depth) of foam, it is impossible to quantify performance. It may be possible to receive most, some or none of the transmitted energy.
- Extremely high liquid level (Overflow) conditions when liquid very near the antenna can cause erroneous readings and measurement failure.

Refer to Eclipse Guided Wave Radar bulletin 57-101.

AGENCY APPROVALS

AGENCY	MODEL	PROTECTION METHOD	AREA CLASSIFICATION
FM  APPROVED	R95-5X0A-1X0	Intrinsically Safe	Class I, Div. 1; Groups A, B, C, & D Class II, Div. 1; Groups E, F, & G Class III, NEMA 4X, T4@80C Entity
	R95-5X0A-3X0	Explosion Proof	Class I, Div. 1; Groups B, C & D Class II, Div. 1; Groups E, F, & G Class III, NEMA 4X, T5@80C
	R95-5X0A-XX0	Non-Incendive ①	Class I, Div. 2; Groups A, B, C, & D Class II, Div. 2; Groups F & G Class III, NEMA 4X
CSA 	R95-5X0A-1X0	Intrinsically Safe	Class I, Div. 1; Groups A, B, C, & D Class II, Div. 1; Groups E, F & G Class III, Type 4X, T4@80C Entity
	R95-5X0A-3X0	Explosion Proof	Class I, Div. 1; Groups B, C & D Class II, Div. 1; Groups E, F, & G Class III, Type 4X, T5@80C
	R95-5X0A-XX0	Non-Incendive ①	Class I, Div. 2; Groups A, B, C, & D Class II, Div. 2; Groups E, F, & G Class III, Type 4X, T4@80C
ATEX 	R05-5X0A-AX0	Intrinsically Safe	ATEX II 1G EEx ia IIC T4
	R05-5X0A-CX0	Explosion Proof	ATEX II 1/2G EEx d IIC T6

① Measured media inside vessel must be non-flammable only.

 These units have been tested to EN 61000-6-2 and EN 61000-6-4 and are in compliance with the EMC Directive 89/336/EEC.

COMMUNICATIONS APPROVALS

Country	Agency	Frequency
US	FCC	6.3 Ghz
Canada	IC	6.3 Ghz
Europe	RTTE	5.8 Ghz

FAILURE MODES, EFFECTS, AND DIAGNOSTIC ANALYSIS (FMEDA) FOR SAFETY INSTRUMENT SYSTEMS (SIS)

Safe Failure Fraction (SFF)	Safety Integrity Level (SIL)	Device Type
73.7%	1	B (complex)

TRANSMITTER SPECIFICATIONS

FUNCTIONAL/PHYSICAL

System Design

Measurement Principle Pulse Burst Radar @ 5.8 GHz (Europe), 6.3 GHz (North America) ①

Input

Measured Variable Liquid level, determined by the time-of-flight of a radar pulse from transmitter to product surface and back

Span 0.5 to 65 feet (0.2 m to 20 m)

Output

Type Analog 4 to 20 mA with HART digital signal

Range Analog 3.8 to 20.5 mA useable (meets NAMUR NE 43)

Digital 0 to 999" (0 to 999 cm)

Resolution Analog 0.01 mA

Digital 0.1"

Loop Resistance GP/IS/XP 350 Ω @ 24 VDC/22 mA;

400 Ω @ 24 VDC/20 mA

Diagnostic Alarm Adjustable 3.6 mA, 22 mA, HOLD (meets NAMUR NE 43)

Damping Adjustable 0–45

User Interface

Keypad 3-button menu-driven data entry and system security

Indication 2-line × 8-character display

Digital Communication ② HART version 5.x compatible

Power (Measured at instrument terminals)

General Purpose 16 to 36 VDC

Intrinsically Safe 16 to 28.6 VDC

Explosion Proof 16 to 36 VDC

Housing

Material Cast aluminum A356T6 (<0.2% copper), cast 316 SS (optional)

Cable Entry ¾" NPT, M20

Net/Gross Weight Aluminum 6 lbs (2.36 kg) / 7 lbs (2.76 kg)

316 Stainless steel 13.5 lbs (5.3 kg) / 14 lbs (5.7 kg)

Overall Dimensions H 10.21" (259 mm) × W 4.38" (111 mm) × D 7.40" (188 mm)

① RTTE: European approval, FCC & IC: North American approval

② HART communicator: Magnetrol P/N 089-5213-XXX sold separately

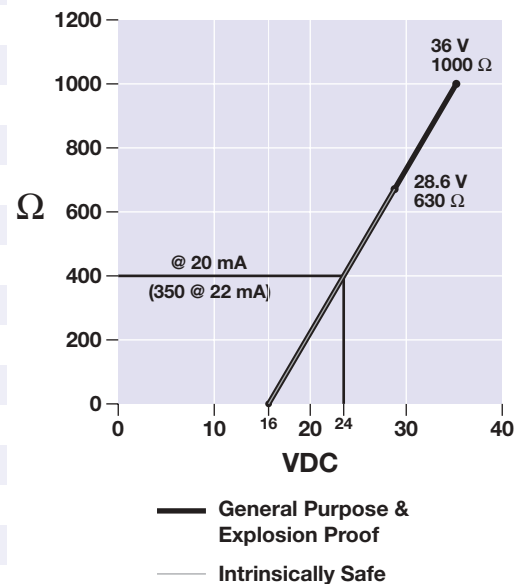

ENVIRONMENT

Operating Temperature -40 to +175° F (-40 to +80° C)

Display Function Operating Temperature -5 to +160° F (-20 to +70° C)

Storage Temperature -50 to +175° F (-40 to +80° C)

Humidity 0–99%, non-condensing

Electromagnetic Compatibility Meets CE requirements: EN 61000-6-2, EN 61000-6-4

Shock Class ANSI/ISA-S71.03 Class SA1

Vibration Class ANSI/ISA-S71.03 Class VC2

PERFORMANCE

Reference Conditions	Reflection from ideal reflector at +70° F (+20° C)
Linearity	±0.4 inch (1 cm) or 0.1% of tank height (whichever is greater)
Measured Error	±0.4 inch (1 cm) or 0.1% of tank height (whichever is greater) (Performance will degrade slightly within 60" (1.5 m) of antenna)
Resolution	0.1 inch (2.5 mm)
Repeatability	±0.2 inch (5 mm) or 0.05% of tank height (whichever is greater)
Response Time	< 1 second
Warm-up Time	30 seconds
Operating Temperature Range	-40° to +175° F (-40° to +80° C) / ATEX EEx d -40° to +160° F (-40° to +70° C)
LCD Operating Temperature Range	-5° to +160° F (-20° to +70° C)
Ambient Temperature Effect	Temperature effect 0.05% per 10° C
Process Dielectric Effect	< 0.3 inch within selected range
Humidity	0-99%, non-condensing
Electromagnetic Compatibility	Meets CE requirements EN-61000-6-2, EN 61000-6-4
Maximum Rate of Change	180 inches (450 cm)/minute

ANTENNA SPECIFICATIONS

FUNCTIONAL / PHYSICAL

Model	Dielectric Rod TFE	Dielectric Rod ^① Polypropylene	4" Horn	6" Horn
Materials	316 SS (Hastelloy C, Monel and Kynar opt.), TFE, Viton® O-rings	316 SS, Polypropylene, Viton® O-rings	316 SS (Hastelloy C opt.), TFE, Viton® O-rings	316 SS (Hastelloy C opt.), TFE, Viton® O-rings
Process Connection	1½" NPT and BSP, ANSI or DIN flanges	1½" NPT and BSP, ANSI or DIN flanges	4" and 6" ANSI or DIN flanges	6" ANSI or DIN flanges
Maximum Process Temperature	+400° F @ 50 psig (+204° C @ 3.5 bar)	+200° F @ 50 psig (+93° C @ 3.5 bar)	+400° F @ 50 psig (+204° C @ 3.5 bar)	+400° F @ 50 psig (+204° C @ 3.5 bar)
Maximum Process Pressure	675 psig @ +70° F (46.5 bar @ +20° C)	750 psig @ +70° F (51.7 bar @ +20° C)	675 psig @ +70° F (46.5 bar @ +20° C)	675 psig @ +70° F (46.5 bar @ +20° C)
Minimum Dielectric (application dependent)	2.0	2.0	1.7	1.7

① All-polypropylene construction optional (see chart below for ratings)

TEMPERATURE / PRESSURE CHART

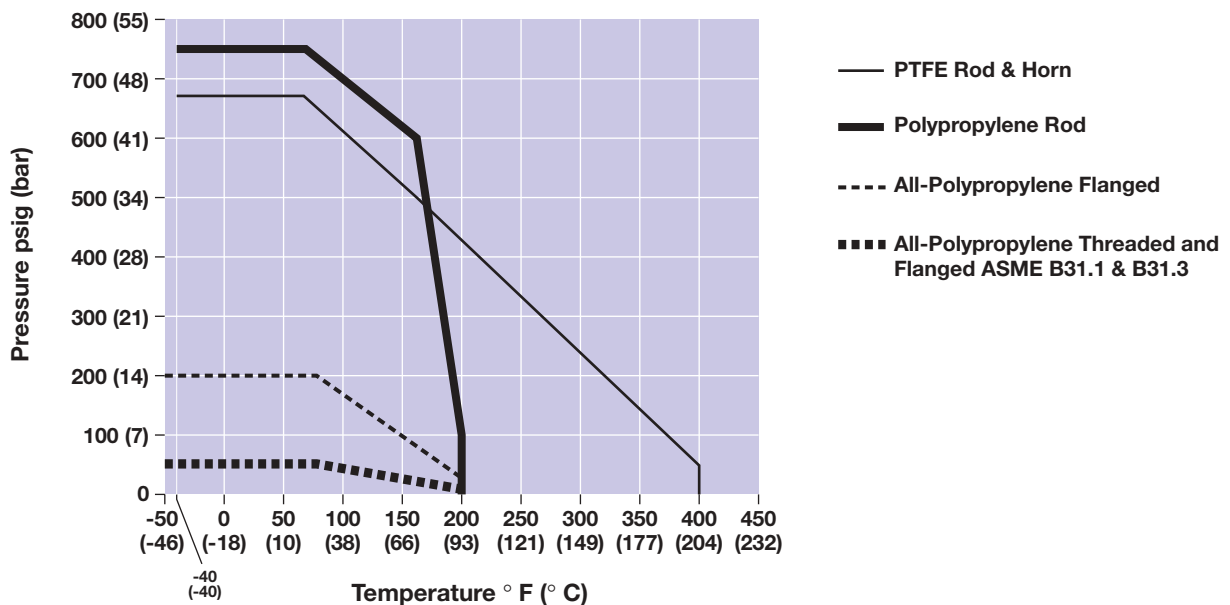

DIMENSIONAL SPECIFICATIONS

INCHES (MM)

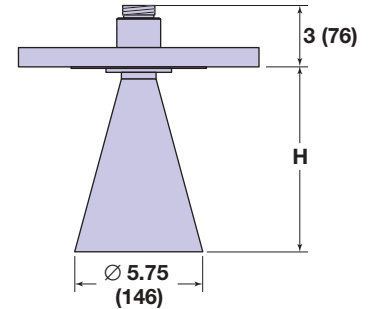
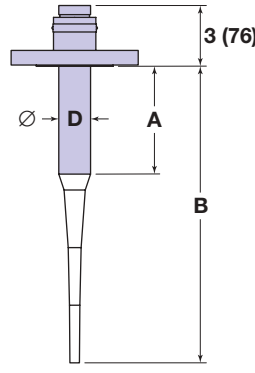
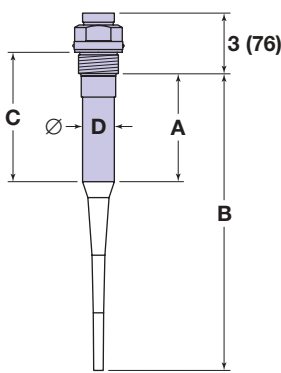
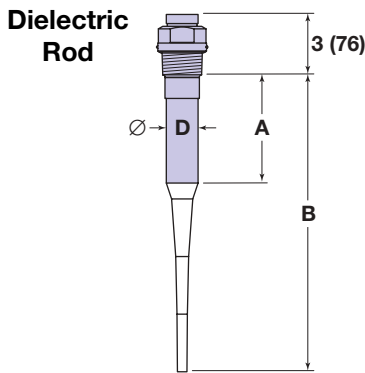
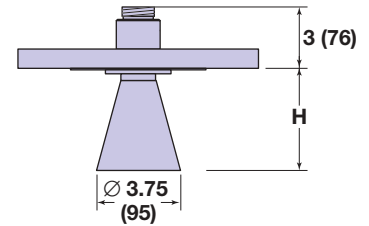
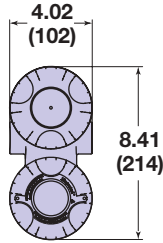
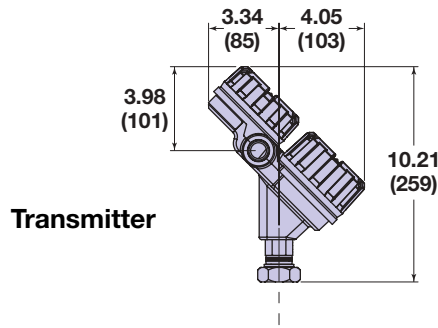

NPT

BSP

ANSI and DIN Flanges

Model #	Antenna Extension (maximum "L" dimension)	DIELECTRIC RODS			HORNS		Antenna Extension O.D. Dimension D	
		All Dim A	All Dim B	BSP Dim C	4" Dim H	6" Dim H	TFE Rod	PP Rod
0	1" (25)	2.3 (58)	11.1 (282)	3.1 (79)	↓	↓	Ø 1.625 (41)	Ø 1.50 (38)
1	4" (100)	5.1 (130)	14.0 (356)	5.9 (150)	4.6 (117)	8.3 (211)	Ø 1.625 (41)	Ø 1.50 (38)
2	8" (200)	9.1 (231)	18.0 (457)	9.9 (251)	8.4 (213)	12.4 (315)	Ø 1.625 (41)	Ø 1.50 (38)
3	12" (300)	13.1 (333)	22.0 (559)	13.9 (353)	12.4 (315)	12.4 (315)	Ø 1.625 (41)	Ø 1.50 (38)

O - R I N G (S E A L) S E L E C T I O N C H A R T

Material	Code	Maximum Temperature	Maximum Pressure	Min. Temp.	Recommended For Use In	Not Recommended For Use In
Viton® GFLT	0	+400° F @ 232 psig (+200° C @ 16 bar)	750 psig @ +70° F (50 bar @ +20° C)	-40° F (-40° C)	General purpose, steam, ethylene	Ketones (MEK, acetone), skydrol fluids, amines, anhydrous ammonia, low molecular weight esters and ethers, hot hydrofluoric or chlorosulfonic acids, sour HCs
EPDM	1	+250° F @ 200 psig (+125° C @ 14 bar)	750 psig @ +70° F (50 bar @ +20° C)	-60° F (-50° C)	Acetone, MEK, skydrol fluids, anhydrous ammonia,	Petroleum oils, di-ester base lubricants, propane, steam
Aegis PF128	8	+400° F @ 232 psig (+200° C @ 16 bar)	750 psig @ +70° F (50 bar @ +20° C)	-4° F (-20° C)	Inorganic and organic acids (including HF and nitric) aldehydes, ethylene, glycols, organic oils, silicone oils, vinegar, sour HCs, steam, amines, ethylene oxide, propylene oxide	Black liquor, Freon 43, Freon 75, Galden, KEL-F liquid, molten sodium, molten potassium
Kalrez (4079)	2	+400° F @ 232 psig (+200° C @ 16 bar)	750 psig @ +70° F (50 bar @ +20° C)	-40° F (-40° C)	Inorganic and organic acids (including HF and nitric) aldehydes, ethylene, glycols, organic oils, silicone oils, vinegar, sour HCs	Black liquor, hot water/steam, hot aliphatic amines, ethylene oxide, propylene oxide, molten sodium, molten potassium

TRANSMITTER

MODEL NUMBER

Models available for quick shipment, usually within one week after factory receipt of a purchase order, through the Expedite Ship Plan (ESP).

BASIC MODEL NUMBER AND OPERATING FREQUENCY

R95	Pulsar through-air radar level transmitter 6.3 GHz pulse radar (North America, FCC, IC)
R05	Pulsar through-air radar level transmitter 5.8 GHz pulse radar (Europe, RTTE)



POWER

5	24 VDC, two-wire
---	------------------

SIGNAL OUTPUT

1	4–20 mA with HART (HART communicator 089-5213-xxx available separately)
---	---

ACCESSORIES

A	Digital display and keypad
---	----------------------------

MOUNTING/CLASSIFICATION

1	Integral, General Purpose & Intrinsically Safe (FM & CSA), Non-incendive (Class 1, Div II) ①
3	Integral, Explosion-Proof (FM & CSA Class I Div. 1, Groups B, C & D)
A	Integral, General Purpose & Intrinsically Safe (ATEX II 1G EEx ia IIC T4)
C	Integral, Explosion-Proof (ATEX II 1/2G EEx d IIC T6)

① Measured media inside vessel must be non-flammable only.

HOUSING/CONDUIT CONNECTION

1	Cast aluminum, dual compartment, 45° / 3/4" NPT (IP66)
2	Cast aluminum, dual compartment, 45° / M20 (IP66)
3	Cast 316 SS, dual compartment, 45° / 3/4" NPT (IP66) ②
4	Cast 316 SS, dual compartment, 45° / M20 (IP66) ②

② Consult factory for delivery.

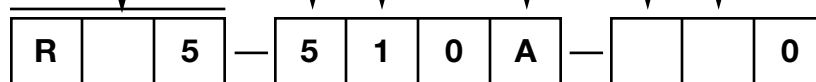

RADAR ANTENNAS

DIELECTRIC ROD MODEL NUMBER

TECHNOLOGY / OPERATING FREQUENCY

R A	Pulsar radar antennas / 5.8/6.3 GHz
-----	-------------------------------------



CONFIGURATION / STYLE

A	Dielectric rod – TFE
B	Dielectric rod – Polypropylene (Material of Construction Code A, G, K, and L only)

MATERIAL OF CONSTRUCTION

A	316/316L stainless steel
B	Hastelloy C
C	Monel
G	All-Polypropylene wetted surfaces (including flange connections)
K	316/316L SS; ASME B31.1 and B31.3 (meets CRN specifications)
L	All-Polypropylene wetted surfaces; ASME B31.1, B31.3 (meets CRN specifications)

PROCESS CONNECTION - SIZE/TYPE ①

31	1½" NPT thread	32	1½" BSP thread
43	2" 150# ANSI raised face flange	DA	DN 50, PN 16 DIN 2527 Form B
44	2" 300# ANSI raised face flange	DB	DN 50, PN 25/40 DIN 2527 Form B
45	2" 600# ANSI raised face flange	DD	DN 50, PN 64 DIN 2527 Form E
53	3" 150# ANSI raised face flange	EA	DN 80, PN 16 DIN 2527 Form B
54	3" 300# ANSI raised face flange	EB	DN 80, PN 25/40 DIN 2527 Form B
55	3" 600# ANSI raised face flange	ED	DN 80, PN 64 DIN 2527 Form E
63	4" 150# ANSI raised face flange	FA	DN 100, PN 16 DIN 2527 Form B
64	4" 300# ANSI raised face flange	FB	DN 100, PN 25/40 DIN 2527 Form B
65	4" 600# ANSI raised face flange	FD	DN 100, PN 64 DIN 2527 Form E
73	6" 150# ANSI raised face flange	GA	DN 150, PN 16 DIN 2527 Form B
74	6" 300# ANSI raised face flange	GB	DN 150, PN 25/40 DIN 2527 Form B
75	6" 600# ANSI raised face flange	GD	DN 150, PN 64 DIN 2527 Form E

SANITARY PROCESS CONNECTIONS

4P	2" Triclover® type, 16 AMP	6P	4" Triclover type, 16 AMP
5P	3" Triclover type, 16 AMP	7P	6" Triclover type, 16 AMP

① Metal flanges welded to antenna; Plastic flanges and metal flanges with threaded antenna connection ordered separately. Refer to Optional Flanges chart on page 15.

O-RINGS ②

0	Viton® GFLT
1	EPDM
2	Kalrez 4079
8	Aegis PF128

② All-Polypropylene antennas (Materials of Construction Codes G and L) use Viton® GFLT O-rings

ANTENNA EXTENSION

0	For nozzle height ≤ 1" (25 mm) (For threaded process connection only)
1	For nozzle height ≤ 4" (100 mm)
2	For nozzle height ≤ 8" (200 mm) (ESP designation for TFE rod only)
3	For nozzle height ≤ 12" (300 mm)

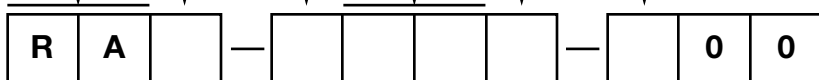

RADAR ANTENNAS

HORN MODEL NUMBER

TECHNOLOGY / OPERATING FREQUENCY

RA	Pulsar radar antennas / 5.8/6.3 GHz
----	-------------------------------------

CONFIGURATION / STYLE

4	4" horn
6	6" horn

MATERIAL OF CONSTRUCTION

A	316/316L stainless steel
B	Hastelloy C
K	316/316L SS; ASME B31.1 and ASME B31.3 (meets CRN specifications)

PROCESS CONNECTION - SIZE/TYPE (metal flanges welded to antenna)

63	4" 150# ANSI raised face flange
64	4" 300# ANSI raised face flange
65	4" 600# ANSI raised face flange
73	6" 150# ANSI raised face flange
74	6" 300# ANSI raised face flange
75	6" 600# ANSI raised face flange
FA	DN 100, PN 16 DIN 2527 Form B
FB	DN 100, PN 25/40 DIN 2527 Form B
FD	DN 100, PN 64 DIN 2527 Form E
GA	DN 150, PN 16 DIN 2527 Form B
GB	DN 150, PN 25/40 DIN 2527 Form B
GD	DN 150, PN 64 DIN 2527 Form E

SANITARY PROCESS CONNECTIONS

6P	4" Triclover type, 16 AMP Sanitary Flange
7P	6" Triclover type, 16 AMP Sanitary Flange

O-RINGS

0	Viton® GFLT
1	EPDM
2	Kalrez 4079
8	Aegis PF128

ANTENNA EXTENSION

1	For nozzle height ≤ 4" (100 mm) - Configuration Style code 4 only
2	For nozzle height ≤ 8" (200 mm)
3	For nozzle height ≤ 12" (300 mm)

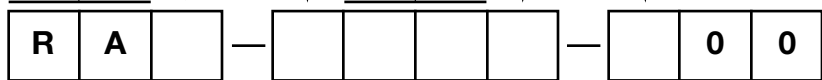

OPTIONAL FLANGES (for use with Antenna Extension Codes 1–3 only)

Part Number: 04-6852	2"		3"		4"		6"	
	150#	300#	150#	300#	150#	300#	150#	300#
316L stainless steel	-001	-005	-002	-006	-003	-007	-004	-008
304L stainless steel	-009	-013	-010	-014	-011	-015	-012	-016
Carbon steel	-017	-021	-018	-022	-019	-023	-020	-024
Hastelloy C	-025	-029	-026	-030	-027	-031	-028	-032
Monel	-033	-037	-034	-038	-035	-039	-036	-040
Kynar	-041	-045	-042	-046	-043	-047	-044	-048
PVC	-049	-053	-050	-054	-051	-055	-052	-056
Polypropylene	-057	-061	-058	-062	-059	-063	-060	-064
TFE	-065	-069	-066	-070	-067	-071	-068	-072

QUALITY



The quality assurance system in place at Magnetrol guarantees the highest level of quality throughout the company. Magnetrol is committed to providing full customer satisfaction both in quality products and quality service.

Magnetrol's quality assurance system is registered to ISO 9001 affirming its commitment to known international quality standards providing the strongest assurance of product/service quality available.

ESP

Expedite **S**hip **P**lan

Several Pulsar Through-Air Radar Level Transmitters are available for quick shipment, usually within one week after factory receipt of a purchase order, through the Expedite Ship Plan (ESP).

Models covered by ESP service are color coded in the selection data charts.

To take advantage of ESP, simply match the color coded model number codes (standard dimensions apply).

ESP service may not apply to orders of ten units or more. Contact your local representative for lead times on larger volume orders, as well as other products and options.

WARRANTY



All Magnetrol electronic level and flow controls are warranted free of defects in materials or workmanship for one full year from the date of original factory shipment.

If returned within the warranty period; and, upon factory inspection of the control, the cause of the claim is determined to be covered under the warranty; then, Magnetrol will repair or replace the control at no cost

to the purchaser (or owner) other than transportation.

Magnetrol shall not be liable for misapplication, labor claims, direct or consequential damage or expense arising from the installation or use of equipment. There are no other warranties expressed or implied, except special written warranties covering some Magnetrol products.

For additional information, see Instruction Manual 58-600.



5300 Belmont Road • Downers Grove, Illinois 60515-4499 • 630-969-4000 • Fax 630-969-9489 • www.magnetrol.com
145 Jardin Drive, Units 1 & 2 • Concord, Ontario Canada L4K 1X7 • 905-738-9600 • Fax 905-738-1306
Heikensstraat 6 • B 9240 Zele, Belgium • 052 45.11.11 • Fax 052 45.09.93
Regent Business Ctr., Jubilee Rd. • Burgess Hill, Sussex RH15 9TL U.K. • 01444-871313 • Fax 01444-871317

Copyright © 2005 Magnetrol International, Incorporated. All rights reserved. Printed in the USA.
Magnetrol and Magnetrol logotype are registered trademarks of Magnetrol International.

Performance specifications are effective with date of issue and are subject to change without notice.
The brand and product names contained within this document are trademarks or registered trademarks of their respective holders.
Viton® is a registered trademark of DuPont Performance Elastomers.

BULLETIN: 58-101.4
EFFECTIVE: June 2005
SUPERSEDES: February 2005