

# L090 SERIES

## BENT STEM FLOAT SWITCHES IDEAL FOR OEM APPLICATIONS

### DESCRIPTION

The "Bent Stem" L090 Float Switch mounts less than 3" into the side of a tank and can detect liquid levels with specific gravities as low as 0.45. L090 material options include stainless steel or Buna-N floats with either brass or stainless steel stem mounts. Various mounting sizes are also available for installation into a mounting boss or directly through the tank wall.

### PRINCIPLE OF OPERATION

A hermetically-sealed reed switch is actuated by an internal magnet within the float. As the float rises and falls with the liquid level, the magnetic field passes the switch encapsulated within the stem and results in a switch state change.



### KEY FEATURES

- Leak-Resistant Construction
- Single-Stage Horizontally-Mounted
- Side-Wall Mounting: Internal
- Broad Media Capability
- Optional Floats, Mounts & Configurations
- Operates on Rising or Falling Level
- Interchangeable NO or NC Operation By Float Inversion
- SPST 50 VA Switch (Standard)

### APPLICATIONS

- Food Processing Equipment
- Food Warmers
- Food Dispensing Systems
- Storage Tanks
- Fuel Dispensing Systems
- Humidity Control Equipment

### DIMENSIONS

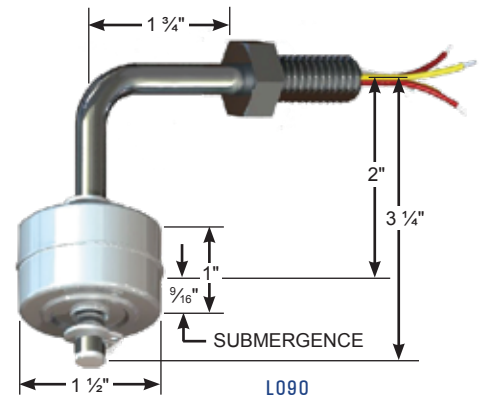

### SPECIFICATIONS

\*SG refers to the recommended minimum liquid specific gravity.

SERIES	MOUNT	STEM/FLOAT	SG*	TEMPERATURE	PRESSURE
L090	1/8" NPT	Brass/Buna	0.63	-40 to +180 °F (-40 to +82.2 °C)	150 PSIG (10.3 bar)
L090	1/8" NPT	Stainless Steel/Buna	0.63	-40 to +180 °F (-40 to +82.2 °C)	150 PSIG (10.3 bar)
L090	1/8" NPT	Stainless Steel	0.70	-40 to +300 °F (-40 to +148.9 °C)	100 PSIG (6.9 bar)
L090	3/8" NPT	Brass/Buna	0.63	-40 to +180 °F (-40 to +82.2 °C)	150 PSIG (10.3 bar)
L090	3/8" NPT	Stainless Steel/Buna	0.63	-40 to +180 °F (-40 to +82.2 °C)	150 PSIG (10.3 bar)
L090	3/8" NPT	Stainless Steel	0.70	-40 to +300 °F (-40 to +148.9 °C)	100 PSIG (6.9 bar)

